

ANNEX 11

Tolerances

1 Specifications of the System of Tolerances

The system of tolerances adopted by the Designer must be clearly indicated in the Project Specific Technical Specifications, either by reference to this Annex or supplemented or modified as appropriate.

2 Terminology

The essential terminology is indicated below.

- a) Warping. Deviation of the actual position of any corner of a face of a flat element from the plane defined by the other three corners (Figure A.11.2.a).



WARPING

Figure A.11.2.a

- b) Bowing. Deviation of the position of any point on the actual surface of a theoretically flat element from the basic flat surface (Figure A.11.2.b).

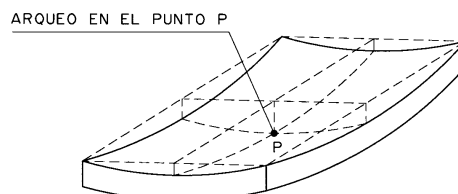

BOWING AT POINT P

Figure A.11.2.b

- c) Ridge (Flange). Projection at the joint between the edges of two adjacent members.
- d) Leaning. See j).
- e) Deviation. Difference between the actual dimension or actual position and the basic dimension or basic position, respectively.
- f) Permitted deviation. Accepted limit for deviation, with its sign (Figure A.11.2.c).
- g) Deviation in level. Vertical deviation of the actual position of a point, straight line or

- plane from the basic position of a horizontal reference plane.
- h) Lateral deviation. Deviation of the actual position of a point or straight line within a horizontal plane from the basic position of a reference point or straight line situated in that plane.
 - i) Relative deviation. Deviation between the actual positions of two elements in a plane, or between adjacent elements in a structure, or the distance from a point, straight line or plane to a reference element.
 - j) Deviation from the vertical. Deviation between the position of a point, line or plane and the basic position of a reference vertical line or vertical plane. When applied to walls or pillars, this is known as leaning.
 - k) Basic dimension or basic position. Dimension or position serving as a reference for establishing the limits of deviation (Figure A.11.2.c).

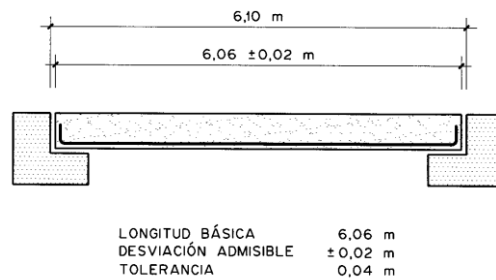

BASIC LENGTH
 PERMITTED DEVIATION
 TOLERANCE

Figure A.11.2.c

- l) Flatness. The degree by which a surface approximates a plane (Figure A.11.2.d).



Figure A. 11.2.d

- m) Straightness. The degree by which a line approximates a straight line (Figure A.11.2.e).



DEVIATION FROM STRAIGHTNESS

Figure A.11.2.e

- n) Hidden surface. The surface of a concrete element intended to be covered with plaster, mortar, boards, etc., or which will not be observed by the user during the working life of the structure.
- ñ) Exposed surface. The surface of a concrete element which will not be covered, except with paint, and which will be observed by the user during the working life of the structure.
- o) Tolerance. The difference between the permitted limits for the deviations of a dimension or position (Figure A.11.2.c). Tolerance is an absolute value without a sign.

For example, for permitted deviations of +30 mm and -20 mm, the tolerance is 50 mm.

3 Selection of the system of tolerances

The tolerances adopted in a design should be as wide as possible but must always be compatible with the due functioning of the structure. Tolerances which do not need to be checked for the purpose of this functioning should not be set.

The system included in this Annex is appropriate for the usual types of concrete structure. For certain specific deviations, several permitted deviations are indicated depending on the types of use or levels of finishing. In all cases, their adaptation to each specific design may require selected modifications.

4 General principles

- a) Tolerances are applied to the dimensions indicated in the drawings. Double dimensioning must be avoided, but, in principle, if several tolerances correspond, in the system described in this document, to one dimension or position, the strictest tolerance shall be understood as applying, unless otherwise indicated.
- b) The structure must not under any circumstances exceed the limits of the property, regardless of the deviations indicated in this Annex.
- c) In the case of fractional dimensions which form part of a total dimension, the tolerances must be interpreted individually and not accumulatively.
- d) Checks must be made before removing timbering, shoring and formwork from those elements in which this operation could cause deformations.
- e) The Constructor must maintain the references and marks allowing the deviations to be measured while the structure is being executed.
- f) The values of the permitted deviations must be chosen from the preferred series of 10, 12, 16, 20, 24, 30, 40, 50, 60, 80 and 100.
- g) If the set tolerances have been met, the elements shall be measured and paid for using the basic dimensions indicated in the drawings, i.e. without taking into account the deviations which have occurred during execution.
- h) If the deviations indicated in this document are exceeded in the structure and could cause problems in its use, the financial penalties laid down for this purpose in the project technical specifications may be applied. However, the acceptance or rejection of the corresponding part of the structure must be based on the study of the effect that these deviations may have on the safety, functionality, durability and appearance of the structure.

5 Permitted deviations

These are always indicated in mm.

5.1 Reinforcements

5.1.1 Passive reinforcements

a) For the cut lengths and bent bars:

$$\text{For } L \leq 6000 \text{ mm} \\ \Delta = -20\text{mm y } +50\text{mm}$$

$$\text{For } L > 6000 \text{ mm} \\ \Delta = -30\text{mm y } +50\text{mm}$$

Being L the straight length of the passive reinforcement bars.

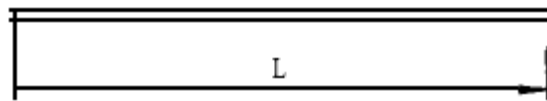

Figure A.11.5.1.1.a1

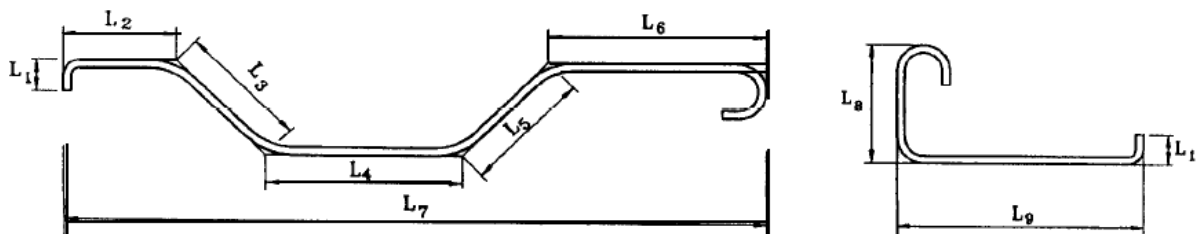

Figure A.11.5.1.1.a2

Moreover, the minimum concrete cover specified in the design and the overlapping lengths defined in this Code must always be guaranteed, being allowed to exceed the +50mm tolerance.

b) For stirrups and hoops:

$$\text{For } \varnothing \leq 25 \text{ mm} \\ \Delta L = \pm 16\text{mm}$$

$$\text{For } \varnothing > 25 \text{ mm} \\ \Delta L = -24\text{mm y } +20\text{mm}$$

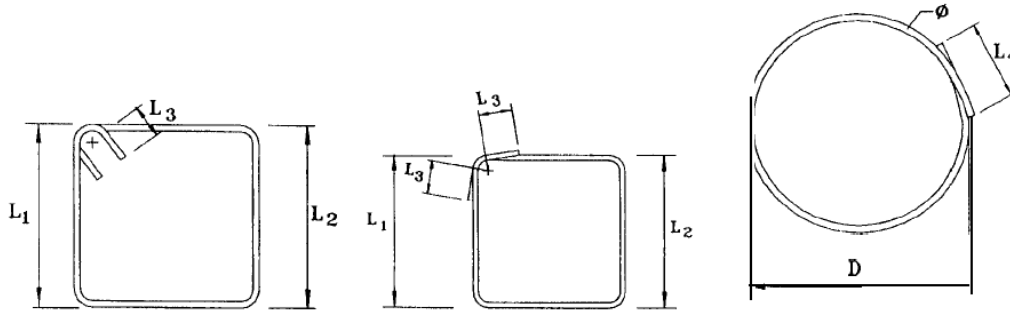

Figure A.11.5.1.1.b1

Being L the length as in figure A.11.5.1.1.b.

Likewise, $|L_1 - L_2| \leq 10\text{mm}$

- c) For the basic position of the axis in parallel bar series, in walls, in slabs, in ground plates, etc:

$$\Delta = \pm 50\text{mm}$$

and the total number of bars being never lower than the specified one.

- d) For the basic position of stirrups and hoops

$$\Delta = \pm b/12 \text{ mm},$$

Being b the smaller dimension of the rectangular section in the pillar or the depth or width of the beam.

Likewise, the number of stirrups and hoops in the structural element stretch never shall be diminished.

- e) For the bending angle in hooks, bents, hooks in U and other curved bars.

$$\Delta = \pm 5^\circ \text{ regarding the design angle}$$

Moreover, the minimum concrete cover specified in the design and the overlapping lengths defined in this Code must always be guaranteed, being allowed to exceed the +50mm tolerance.

5.1.2 Active reinforcements

- a) With regard to the position of prestressing tendons, in comparison with the position defined in the design:

For $l \leq 200 \text{ mm}$

For tendons which are part of a cable, single tendons and strands:

$$\Delta = \pm 0,025l$$

For $l > 200 \text{ mm}$

For tendons which are part of a cable and for single tendons:

$$\Delta = \pm 0,025l \text{ or } \Delta = \pm 20 \text{ mm (whichever is greater).}$$

For strands: $\Delta = \pm 0,04l \text{ or } \Delta = \pm 30 \text{ mm (whichever is greater).}$

where l indicates the depth or width of the cross-section.

- b) Tolerances other than those defined in paragraph a) may be used if it is proven that these do not reduce the required level of safety.
- c) Tolerances for concrete cover. The deviation of the cover shall not exceed the following values:

±5 mm in precast elements
±10 mm in site-cast elements

5.2 Foundations

- a) Horizontal variation of the centre of gravity of isolated foundations (see f) for piles) (Figure A.11.5.2.a)

2% of the dimension of the foundation in the corresponding direction, without exceeding ±50 mm.

- b) Levels

- Upper face of blinding concrete
 - +20 mm
 - 50 mm
- Upper face of foundation (see g) for piles)
 - +20 mm
 - 50 mm
- Thickness of blinding concrete
 - 30 mm

- c) Horizontal dimensions (a_1 -a or b_1 -b) (Figure A.11.5.2.b).

- Formwork-cast foundations
 - +40 mm
 - 20 mm
- Foundations cast against the ground
 - Dimension no greater than 1 m
 - +80 mm
 - 20 mm
 - Dimension greater than 1 m but no greater than 2,5 m
 - +120 mm
 - 20 mm
 - Dimension greater than 2,5 m
 - +200 mm
 - 20 mm

- d) Dimensions of the cross-section (at least those set in paragraph 5.3.d)

+5% >/ 120 mm
-5% </ 20 mm

- e) Flatness.

Deviations measured after hardening and within 72 hours of the concrete being placed, using a 2 m rule placed on any part of the upper face of the foundation and supported on any two points (not applicable to elements with a dimension less than 2 m).

Of blinding concrete:
±16 mm

Of the upper face of the foundation:

±16 mm

Of side faces (only for formwork-cast foundations):

±16 mm

- f) Horizontal deviation of the centre of gravity of the upper face of a pile
Limited execution control:
±150 mm
Normal execution control:
±100 mm
Intensive execution control:
±50 mm
- g) Deviation in the level of the upper face of a pile, once the head has been uncovered
-60 mm
+30 mm
- h) Deviation in the diameter d of the pile section
 $+0,1d > / +100$ mm
-20 mm

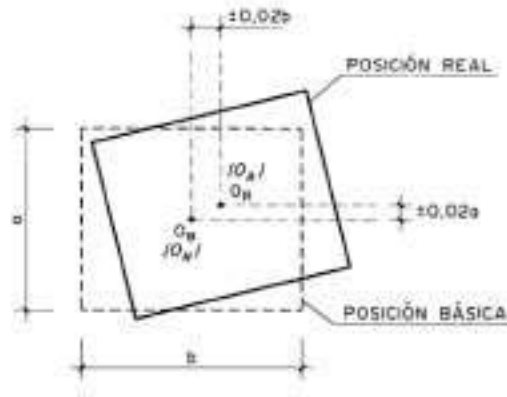

ACTUAL POSITION

BASIC POSITION

Figure A.11.5.2.a



Figure A.11.5.2.b

5.3 Site-cast structural elements of buildings

a) Deviation from the vertical

Where H is the height of the point in question from the horizontal plane taken as the reference.

a-1) Lines and surfaces in general (Δ in mm for H in m)

$H \leq 6$ m	$\Delta = \pm 24$ mm	
$6 \text{ m} < H \leq 30$ m	$\Delta = \pm 4H$	$\nlessgtr \pm 50$ mm
$H \geq 30$ m	$\Delta = \pm 5H/3$	$\nlessgtr \pm 150$ mm

a-2) Outer edge of pillars with exposed corners and exposed vertical expansion joints (Δ in mm for H in m)

$H \leq 6$ m	$\Delta = \pm 12$ mm	
$6 \text{ m} < H \leq 30$ m	$\Delta = \pm 2H$	$\nlessgtr \pm 24$ mm
$H \geq 30$ m	$\Delta = \pm 4H/5$	$\nlessgtr \pm 80$ mm

b) Lateral deviations

- Members in general

$$\Delta = \pm 24 \text{ mm}$$

- Voids in slabs and floor slabs. Deviation from the centre for voids with a dimension in the direction in question up to 30 cm
 $\Delta = \pm 12 \text{ mm}$
- Voids in floor slabs. Deviation from the edges for voids with dimensions in the direction in question greater than 30 cm
 $\Delta = \pm 12 \text{ mm}$
- Joints in general
 $\Delta = \pm 16 \text{ mm}$

c) Deviations in level

c-1) Upper face of slabs

c-1.1) Upper face of pavement slabs

$$\pm 20 \text{ mm}$$

c-1.2) Upper face of slabs and floor slabs, before removing shoring

$$\pm 20 \text{ mm}$$

c-1.3) Formwork-cast lower face of members, before removing shoring

$$\pm 20 \text{ mm}$$

c-1.4) Lintels, parapets and gutters and also exposed horizontal projections

$$\pm 12 \text{ mm}$$

d) Dimensions of the cross-section

Squareness of beams, pillars and piers, depth of slabs and floor slabs, and thickness of walls (Dimension D)

$$D \leq 30 \text{ cm}$$

$$+10 \text{ mm}$$

$$-8 \text{ mm}$$

$$30 \text{ cm} < D \leq 100 \text{ cm}$$

$$+12 \text{ mm}$$

$$-10 \text{ mm}$$

$$100 \text{ cm} < D$$

$$+24 \text{ mm}$$

$$-20 \text{ mm}$$

e) Relative deviation

e-1) Staircases (applicable to staircases in which the steps are made from the concrete itself, without any covering material).

Difference in height between consecutive risers:

$$3 \text{ mm}$$

Difference in width between consecutive treads:

$$6 \text{ mm}$$

e-2) Gutters and projections

Basic width less than 50 mm

$$\pm 3 \text{ mm}$$

Basic width between 50 and 300 mm

$$\pm 6 \text{ mm}$$

e-3) Deviation of the formwork-cast face of elements from the theoretical plane, in 3 m

e-3.1) Deviation from the vertical of outer edges of exposed pillars and joints in exposed concrete

$$\pm 6 \text{ mm}$$

- e-3.2) Other elements
 - ± 10 mm
- e-4) Relative deviation between consecutive panels of formwork for surface elements (the corresponding Class must be selected in the design)
 - Class A surface
 - ±3 mm
 - Class B surface
 - ±6 mm
 - Class C surface
 - ±12 mm
 - Class D surface
 - ±24 mm
- e-5) Flatness of the finish of pavement slabs, slabs and floor slabs

Vertical deviation measured using a 3 m rule placed on any part of the slab or floor slab and supported on two points, before removing the shoring, after the concrete has hardened and within the first 72 hours after placing.

Surface finish:

 - Mechanical flattening (rotary type)
 - ±12 mm
 - Screeding using a float
 - ±8 mm
 - Smooth
 - ±5 mm
 - Very smooth
 - ±3 mm

With regard to the flatness of the finish, tolerances must not be set for not scaffolded slabs and floor slabs as the shrinkage and deflection may significantly affect the measurement of the deviations.

The rule method is very imperfect and nowadays tends to be replaced by the statistical evaluation of flatness and leveling measurements.
- f) Openings in elements
 - f-1) Dimensions of the cross-section
 - +24 mm
 - 6 mm
 - f-2) Location of the centre
 - ±12 mm

5.4 Precast members (not applicable to precast piles)

In general, for precast elements which have CE marking, the required tolerances will be those set in the corresponding harmonised European product standard. The tolerances set in paragraphs 5.4.1, 5.4.2 and 5.4.3 will only apply in the case of elements without CE marking.

5.4.1 Manufacturing tolerances of linear elements

- a) Length of member, L
 - ± 0,001 L
 - With a minimum of 5 mm for lengths up to 1 m and 20 mm for longer lengths.
- b) Transverse dimensions, D
 - $D \leq 150$ mm
 - ±3 mm
 - $150 \text{ mm} < D \leq 500$ mm
 - ±5 mm
 - $500 \text{ mm} < D \leq 1000$ mm
 - ±6 mm

$$D > 1000 \text{ mm}$$

$$\pm 10 \text{ mm}$$

- c) Lateral deflection, measured from the vertical plane containing the axis of the member, shall not exceed $L/750$. In addition, depending on the span L , the following must be met:
- $L \leq 6 \text{ m}$
 - $\pm 6 \text{ mm}$
 - $6 \text{ m} < L \leq 12 \text{ m}$
 - $\pm 10 \text{ mm}$
 - $L > 12 \text{ m}$
 - $\pm 12 \text{ mm}$
- d) Deviation of the camber from the basic design value, measured during assembly
- Members in general
 - $\pm \frac{L}{750}$ with a limit value of 16 mm
 - Consecutive members during placing
 - $\pm \frac{L}{1000}$ with a limit value of 12 mm

Where L is the length of the member. The second condition only applies where the deviation affects the aesthetic appearance.

- e) Flatness of the surface of the upper face. Deviation measured using a 3 m rule placed on any two points, during assembly.
- e-1) If the elements do not have to receive a site-cast concrete top slab
 - $\pm 6 \text{ mm}$
 - e-2) If the elements do have to receive a site-cast concrete top slab
 - $\pm 12 \text{ mm}$

5.4.2 Manufacturing tolerances of surface elements

- a) Length, where L is the basic dimension
- $L \leq 6 \text{ m}$
 - $\pm 8 \text{ mm}$
 - $6 \text{ m} < L \leq 12 \text{ m}$
 - +12 mm
 - 16 mm
 - $L > 12 \text{ m}$
 - +16 mm
 - 20 mm
- b) Deviations in the dimensions of the cross-section (D)
- $D \leq 60 \text{ cm}$
 - $\pm 6 \text{ mm}$
 - $60 \text{ cm} < D \leq 100 \text{ cm}$
 - $\pm 8 \text{ mm}$
 - $D > 100 \text{ cm}$
 - $\pm 10 \text{ mm}$
- c) Openings in panels
- Dimensions at the opening
 - $\pm 6 \text{ mm}$

- Position of the central lines of the opening
 - ±6 mm
- d) Embedded elements
 - Screws
 - ±6 mm
 - Welded plates
 - ±24 mm
 - Anchorage
 - ±12 mm
- e) Warping measured during assembly
 - ±5 mm per metre of distance to the closest of the adjacent corners, but no more than ±24 mm.
- f) Bowing (where D is the length of the diagonal of the member)
 - ±0,003 D with a limit value of 24 mm

5.4.3 Assembly deviations

- a) Deviations from the vertical: paragraph 5.3.a applies.
- b) Lateral deviations: paragraph 5.3.b applies.
- c) Deviations in level: paragraph 5.3.c applies.
- d) Deviations in panel walls
 - d-1) Width of joint at exposed panels
 - ±6 mm
 - d-2) Variation in width along the joint between two exposed panels:
 - ±2 mm per metre and at least ±1,5 mm between any two points along the joint, without exceeding ±6 mm under any circumstances
 - d-3) Flanges between two adjacent panels
 - if $L \leq 6$ m ±6 mm
 - if $6 \text{ m} < L \leq 9$ m ±12 mm
 - if $9 \text{ m} < L \leq 12$ m ±24 mm
- e) Deviation in level between edges of upper faces of adjacent members
 - e-1) If they are to receive a top slab
 - ±16 mm
 - e-2) If they are not to receive a top slab
 - ±6 mm
 - e-3) Roof members without any top slab
 - ±16 mm
 - e-4) Elements with functions as guides or screeds
 - ±2 mm
- f) Placement of loadbearing and semi-loadbearing joists in floor slabs
 - f-1) Deviation of the flooring block support on a beam, d_1 (Figure A.11.5.4.3.a)
 - ±5 mm with a limit value of $d_1/3$
 - measured with regard to the basic dimension indicated in the Authorisation for Use.
 - In practice, it is easier to control this permitted deviation by controlling the deviation of the distance between beam axes, limited to
 - $$\pm 10 \text{ mm} > / \pm \frac{2d_1}{3}$$

f-2) Bearing of beams or reinforcements projecting from beams (Figure A.11.5.4.3.b).

Edge beams (Length L_1)

± 15 mm

Inner beams (Length L_2)

± 15 mm

f-3) Thickness of top slab, measured by submerging a nail in the fresh concrete, at a flooring block bonding key. The position of the bonding key is determined by feeling with the nail.

-6 mm

+10 mm

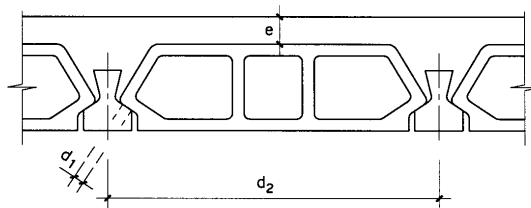

Figure A.11.5.4.3.a

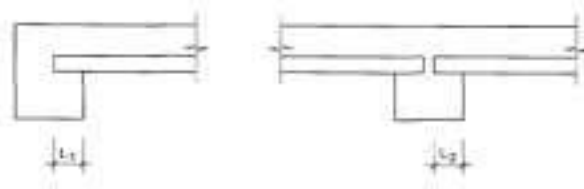

Figure A.11.5.4.3.b

5.5 Core walls, cores, towers, chimneys, piers and other elements concreted using slipforms

a) Deviation from the vertical. Horizontal slippage from the basic position of any reference point at the base of the element, depending on the height H .

$H \leq 30$ m $\Delta = \pm 1,5H$ with a limit value of 12 mm

$H > 30$ m $\Delta = \pm \frac{2}{5} H$ with a limit value of 100 mm

where Δ in mm and H in m

b) Lateral deviation between adjacent elements
 ± 50 mm

- c) Thickness of internal and external walls
 - Thickness no greater than 25 cm
 - +12 mm
 - 10 mm
 - Thickness greater than 25 cm
 - +16 mm
 - 10 mm
- d) Relative deviation of formwork-cast flat surfaces

These may deviate from the basic flat position without exceeding ± 6 mm in 3 m.

5.6 Retaining walls and basement walls

- a) Deviation from the vertical. Horizontal slippage of any point of the elevation from the basic position of any reference point situated on the upper face of the foundation, depending on the height H .
 - $H \leq 6$ m
 - Extrados
 - ± 30 mm
 - Intrados
 - ± 20 mm
 - $H > 6$ m
 - Extrados
 - ± 40 mm
 - Intrados
 - ± 24 mm
- b) Thickness e :
 - $e \leq 50$ cm
 - +16 mm
 - 10 mm
 - $e > 50$ cm
 - +20 mm
 - 16 mm

For walls concreted against the ground, the maximum deviation will be +40 mm.

- c) Relative deviation of the flat intrados or extrados surfaces.

These may deviate from the basic flat position without exceeding ± 6 mm in 3 m.
- d) Deviation in level of the upper edge of the intrados, for exposed walls:
 - ± 12 mm
- e) Finishing tolerance of the upper face of the elevation, for exposed walls:
 - ± 12 mm using a 3 m rule supported on any two points, once the concrete has hardened.

5.7 Hydraulic and sanitary works

5.7.1 Channels

- a) Lateral deviation
 - Straight sections
 - ± 50 mm
 - Curved sections
 - ± 100 mm

- b) Width of the section at any level, where B is the basic width:
 $\Delta = \pm(2,5B+24)$ mm
with Δ in mm for B in metres
- c) Deviation in level
 - c-1) Floor
 ± 12 mm
 - c-2) Top of side walls where H is the total depth
 $\Delta = \pm(5H+24)$ mm
with Δ in mm for H in metres
- d) Thickness e of floors and side walls
 $\pm e/10$, provided that the basic value is maintained, determined as the average of the measurements at any three points which are 10 m apart along the channel.

5.7.2 Drains, siphons, etc.

- a) Lateral deviation
 - a-1) Axis line
 ± 24 mm
 - a-2) Position of points on the inner surface, where D is the maximum internal dimension:
 $\Delta = \pm 5D$ mm with a limit value of 12 mm
with Δ in mm for D in m
- b) Deviation in level
 - b-1) Floors or bottoms
 ± 12 mm
 - b-2) Surfaces of side walls ± 12 mm
- c) Dimension e of the thickness
 - $e \leq 30$ cm
 $+0,05e < /12$ mm
 -8 mm
 - $e > 30$ cm
 $+0,05e < /16$ mm
 $-0,025e > /-10$ mm

5.8 Site-cast bridges and similar structures (for slip piers, see 5.5)

- a) Deviation from the vertical
 - Exposed surfaces
 ± 20 mm
 - Concealed surfaces
 ± 40 mm
- b) Lateral deviation
 - Axis
 ± 24 mm
- c) Deviation in level
 - Upper face of concrete surfaces and horizontal mouldings and channels
 - Exposed
 ± 20 mm
 - Concealed

±40 mm

- d) Flatness of paving
Longitudinal direction
3 mm using a 3 m rule supported on any two points, once the concrete has hardened and within 72 hours of placing.
Transverse direction
6 mm using a 3 m rule supported on any two points, once the concrete has hardened and within 72 hours of placing.
- e) Pavements and ramps
In any direction:
6 mm using a 3 m rule supported on any two points, once the concrete has hardened and within 72 hours of placing.
- f) Dimensions of the cross-section
- f-1) Thickness e of the top slab
 $e \leq 25$ cm
+10 mm
-8 mm
 $e > 25$ cm
+12 mm
-10 mm
- f-2) Transverse dimensions, D , of piers, beams, walls, stirrups, etc.
 $D \leq 30$ cm
+10 mm
-8 mm
 $30 \text{ cm} < D \leq 100 \text{ cm}$
+12 mm
-10 mm
 $D > 100$ cm
+16 mm
-12 mm
- f-3) Dimensions of voids in concrete elements
±12 mm
- g) Relative deviation
- g-1) Position of voids in concrete elements
±12 mm
- g-2) Formwork-cast flat surfaces with regard to the basic position of the plane.
Deviations in 3 m.
Exposed surfaces
±12 mm
Concealed surfaces
±24 mm
- g-3) Surfaces not cast in formwork, apart from paving and pavements, with regard to the basic position of the reference plane. Deviations:
In 3 m
±6 mm
6 m
±10 mm

5.9 Paving and pavements (not applicable to roads)

- a) Lateral deviations
 - a-1) Position of tie rods. Deviation from the axis
 ± 24 mm
 - a-2) Deviation of tie rods from the axis of the paving (slippage of the end of the tie rod in the direction of the joint)
 ± 6 mm
- b) Flatness deviations
 - b-1) In the longitudinal direction:
3 mm using a 3 m rule supported on any two points, once the concrete has hardened and within 72 hours of placing.
 - b-2) In the transverse direction:
6 mm using a 3 m rule supported on any two points, once the concrete has hardened and within 72 hours of placing.
 - b-3) Pavements and ramps. In any direction:
6 mm using a 3 m rule supported on any two points, once the concrete has hardened and within 72 hours of placing.

5.10 Civil works, involving very thick elements, not included in other sections

- a) Deviation from the vertical
 - Exposed surfaces
 ± 30 mm
 - Hidden surfaces ± 50 mm
- b) Lateral deviation
 - Exposed surfaces
 ± 30 mm
 - Hidden surfaces
 ± 50 mm
- c) Deviation in level
 - Exposed surfaces, floated or formwork-cast
 ± 12 mm
 - Hidden, floated or formwork-cast
 ± 24 mm
- d) Relative deviation
 - d-1) Formwork-cast flat surfaces with regard to the basic position of the plane. Deviations in 3 m.
 - Exposed surfaces
 ± 12 mm
 - Concealed surfaces
 ± 24 mm
 - d-2) Surfaces not cast in formwork, apart from pavements and sidewalks, with regard to the basic position of the reference plane. Deviations:
 - In 3 m
 ± 6 mm
 - In 6 m
 ± 10 mm

6 Applicable tolerances for reducing the partial safety factors for materials

6.1 Site-cast structures

In accordance with the criteria defined in Article 15.3.1 of this Code, the partial safety factor for steel may be reduced to the value indicated in this section, provided that it is ensured that the geometric deviation in the position of the reinforcement (Δc) is within the limits given in Table A.11.6.1.a.

Table A.11.6.1.a

Limit of the deviation in the position of reinforcements

Dimension h or b (mm)	Position of the reinforcement $\pm\Delta c$ (mm)
≤ 150	5
400	10
≥ 2500	20

Note 1: The intermediate values may be determined by linear interpolation.

Note 2: Δc refers to the mean value determined for passive reinforcements or for prestressing tendons in the cross-section or in a width of 1.0 m in the case of slabs or walls.

Likewise, in accordance with the criteria defined in Article 15.3.2 of this Code, the partial safety factor for concrete may be reduced to the value indicated in paragraph 3, provided that it is ensured that the geometric deviations in the cross-section (Δh , Δb) from the nominal dimensions are within the limits given in Table A.11.6.1.b.

Table A.11.6.1.b

Limit of the geometric deviations in the loadbearing section

Dimension h or b (mm)	Cross-section $\pm\Delta h, \Delta b$ (mm)
≤ 150	5
400	10
≥ 2500	30

Note 1: The intermediate values may be determined by linear interpolation.

6.2 Precast elements

The rules laid down in section 6.1 for site-cast structures also apply to precast elements as defined above.

In the specific case of precast elements, the partial safety factor for concrete may be reduced as laid down in Article 15.3.2 of this Code if the loadbearing capacity of the section is calculated using either the actual values measured in the finished structure or a reduced loadbearing section with critical geometric dimensions determined from the nominal values reduced by the deviations contained in section 6.1 of this Annex.

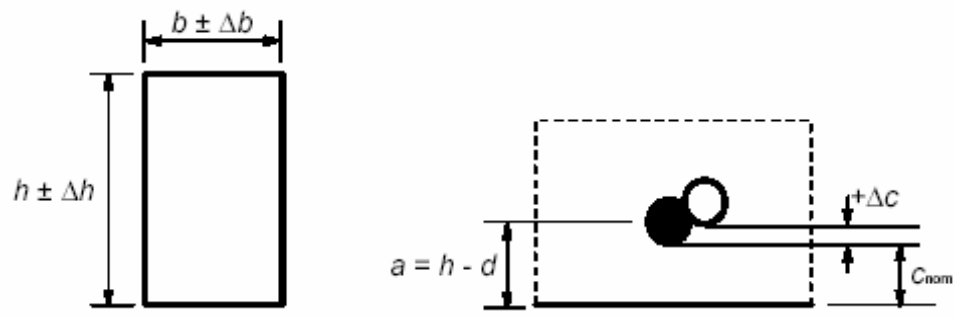

a) Sección transversal

b) Posición de la armadura
(en la dirección desfavorable para el cálculo del canto útil)

a) Cross-section

b) Position of the reinforcement
(in the unfavourable direction for calculating the effective depth)

Figure A.11.6.2. Reduced load bearing section