

T = 23,68 M2
 D = 0,00 M2
 Tv= 3,00 M2
 PERALTE IZQ.= -1,07%
 PERALTE DER.= -1,07%

PK 0+150

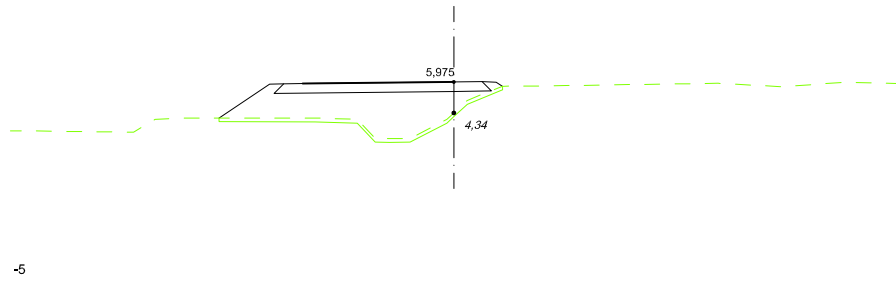

T = 26,61 M2
 D = 0,00 M2
 Tv= 3,30 M2
 PERALTE IZQ.= -0,60%
 PERALTE DER.= -0,60%

PK 0+140

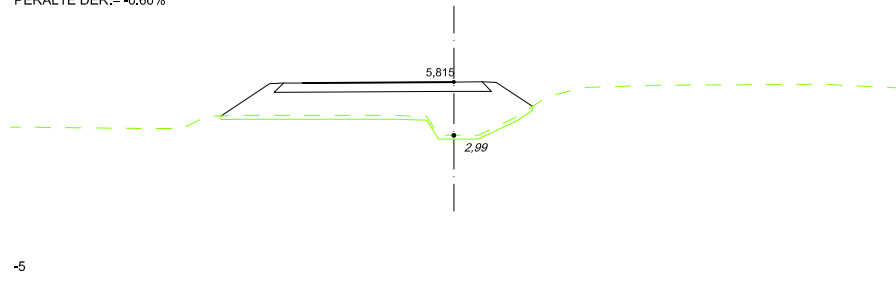

T = 23,55 M2
 D = 0,00 M2
 Tv= 3,49 M2
 PERALTE IZQ.= -0,13%
 PERALTE DER.= -0,13%

PK 0+130

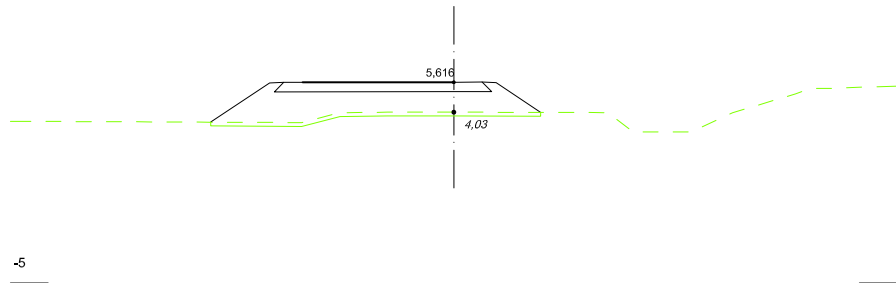

T = 29,03 M2
 D = 0,00 M2
 Tv= 3,31 M2
 PERALTE IZQ.= -2,00%
 PERALTE DER.= -2,00%

PK 0+169,632

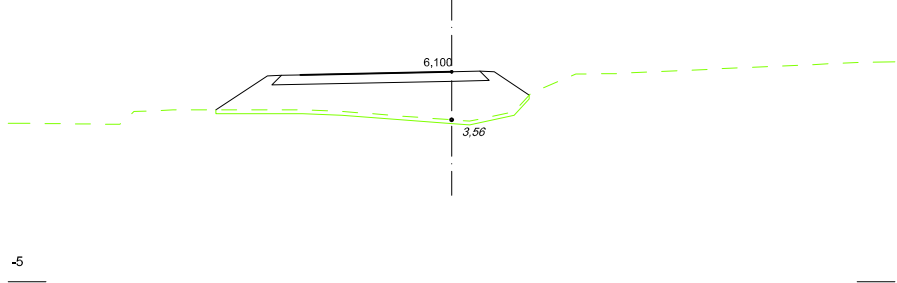

T = 18,98 M2
 D = 0,00 M2
 Tv= 2,51 M2
 PERALTE IZQ.= 0,34%
 PERALTE DER.= 0,34%

PK 0+120

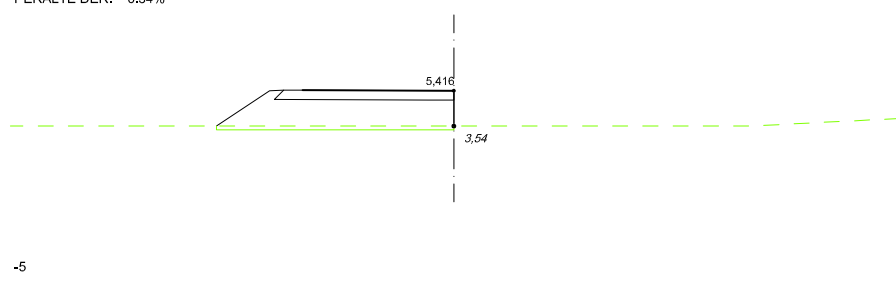

T = 23,84 M2
 D = 0,00 M2
 Tv= 3,02 M2
 PERALTE IZQ.= -1,55%
 PERALTE DER.= -1,55%

PK 0+160

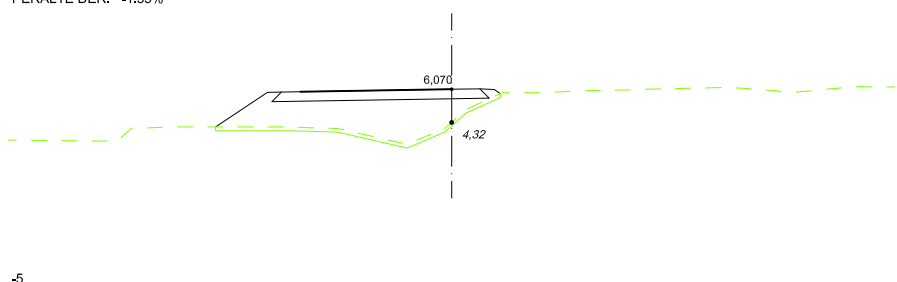

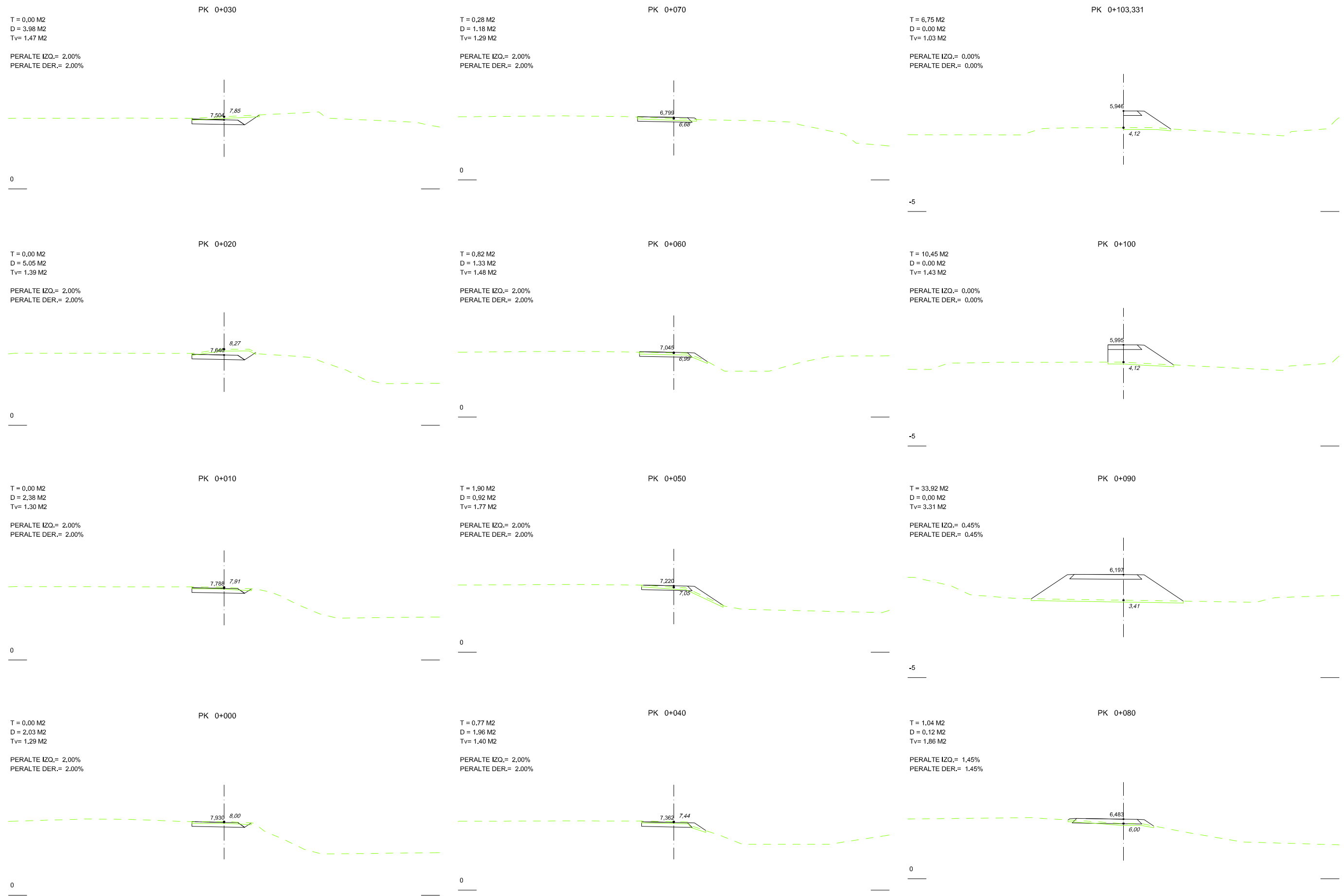

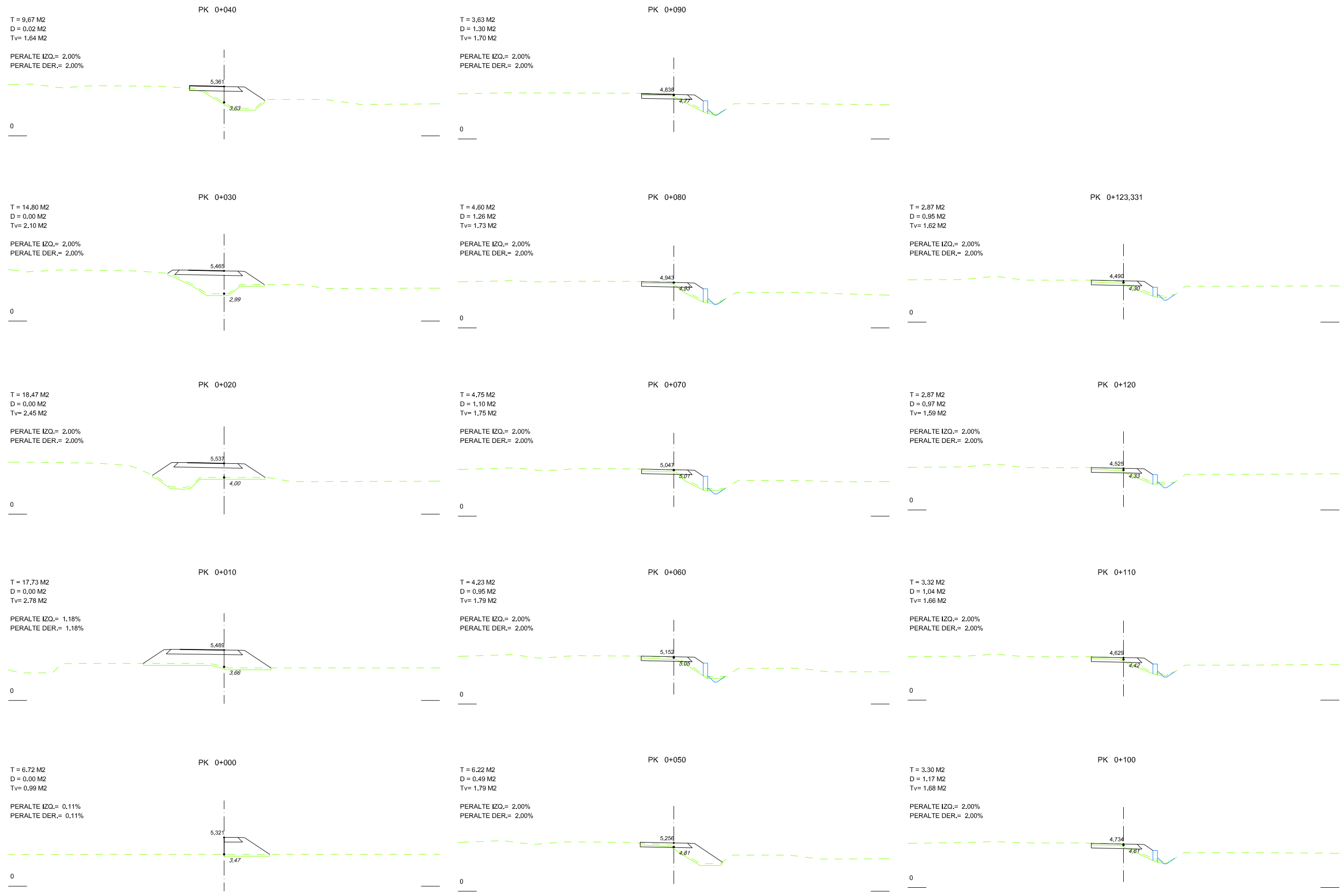

T = 15,04 M2
D = 2,72 M2
Tv = 3,29 M2

PERALTE IZQ.= 0,07%
PERALTE DER.= 2,00%

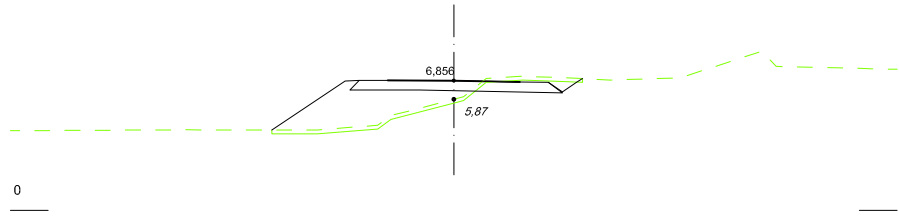

T = 3,40 M2
D = 3,50 M2
Tv = 3,02 M2

PERALTE IZQ.= 2,00%
PERALTE DER.= 2,00%

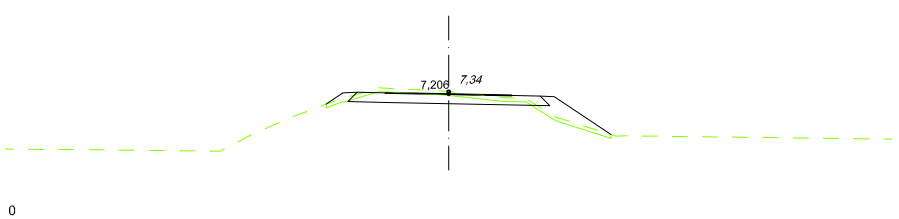

T = 27,81 M2
D = 0,00 M2
Tv = 3,24 M2

PERALTE IZQ.= -0,93%
PERALTE DER.= 2,00%

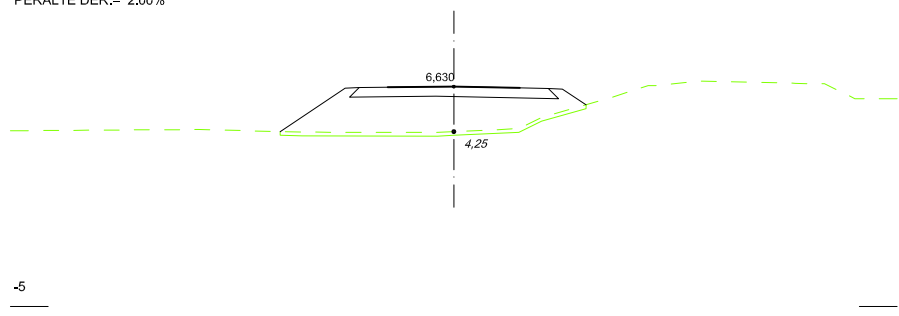

T = 3,55 M2
D = 2,80 M2
Tv = 2,91 M2

PERALTE IZQ.= 2,00%
PERALTE DER.= 2,00%

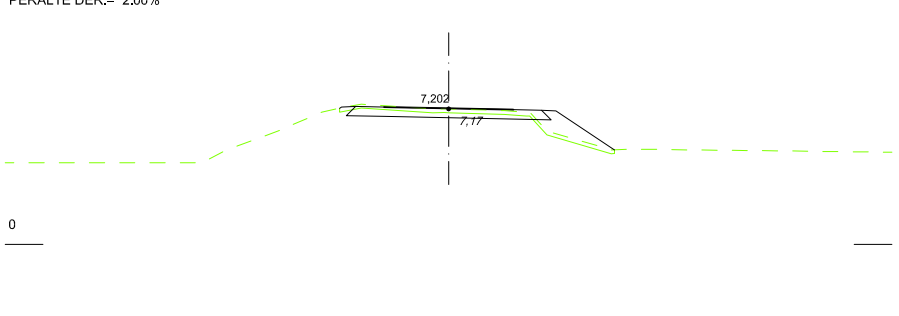

T = 3,10 M2
D = 3,08 M2
Tv = 3,17 M2

PERALTE IZQ.= -2,00%
PERALTE DER.= 2,00%

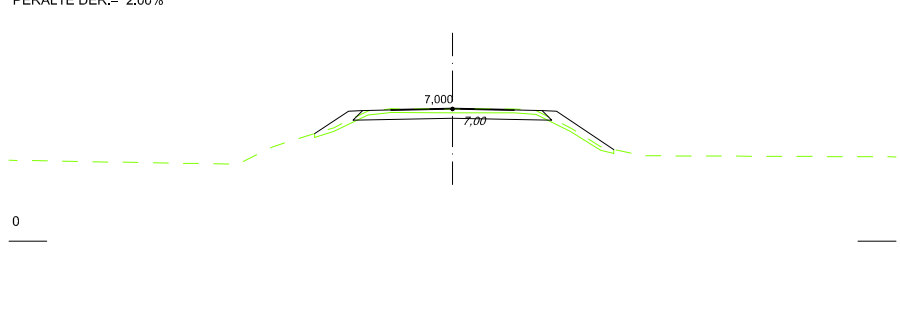

T = 30,47 M2
D = 0,00 M2
Tv = 3,61 M2

PERALTE IZQ.= -1,93%
PERALTE DER.= 2,00%

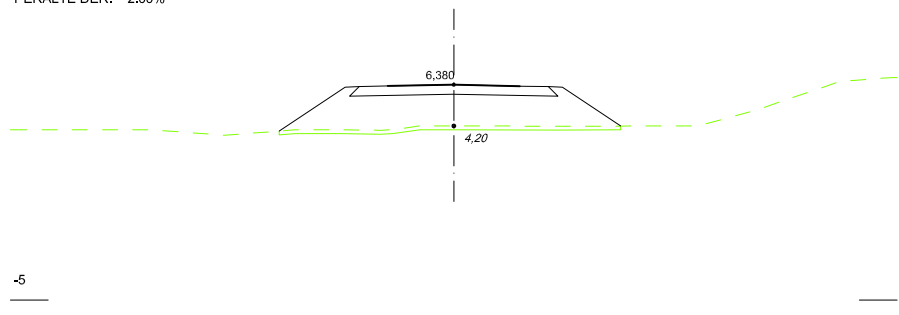

T = 0,00 M2
D = 3,73 M2
Tv = 2,55 M2

PERALTE IZQ.= 2,00%
PERALTE DER.= 2,00%

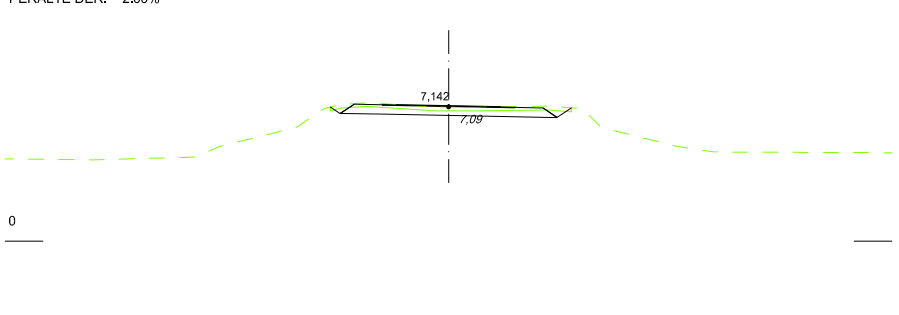

T = 3,72 M2
D = 3,20 M2
Tv = 3,21 M2

PERALTE IZQ.= -0,49%
PERALTE DER.= 2,00%

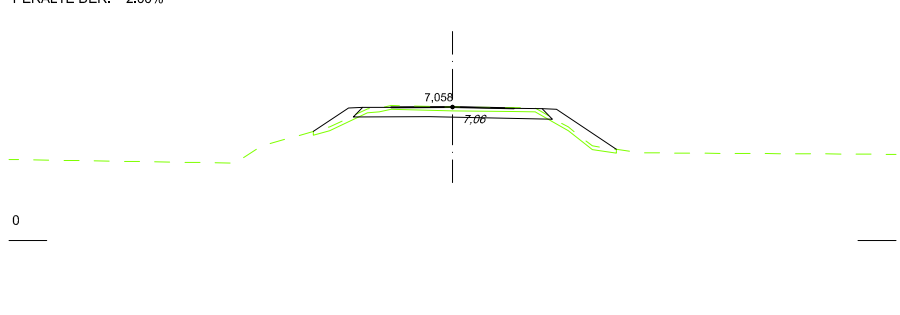

T = 30,68 M2
D = 0,00 M2
Tv = 3,45 M2

PERALTE IZQ.= -2,00%
PERALTE DER.= 2,00%

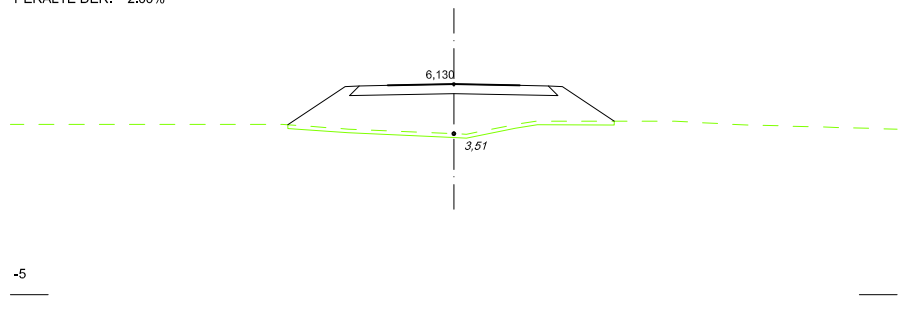

T = 3,46 M2
D = 5,05 M2
Tv = 3,08 M2

PERALTE IZQ.= 1,07%
PERALTE DER.= 2,00%

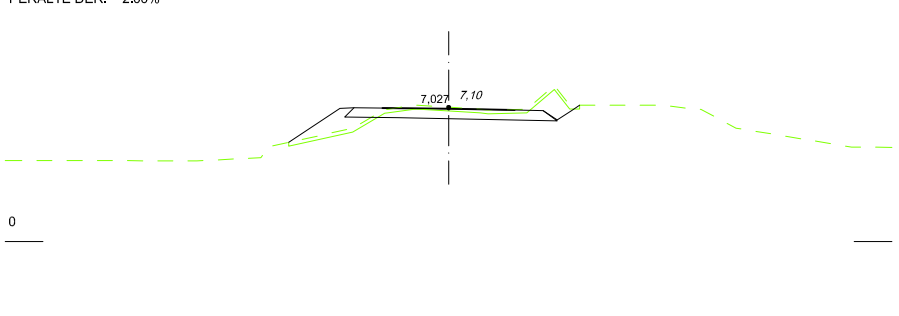

T = 3,69 M2
D = 2,92 M2
Tv = 3,22 M2

PERALTE IZQ.= 2,00%
PERALTE DER.= 2,00%

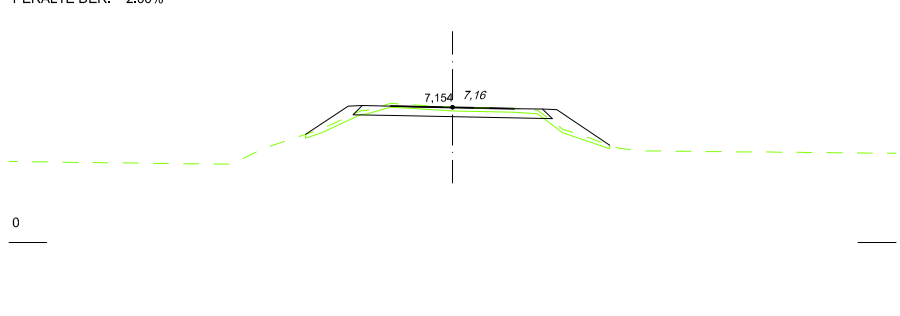

T = 14,92 M2
 D = 0,00 M2
 Tv= 1,73 M2
 PERALTE IZQ.= 1,73%
 PERALTE DER.= 1,73%

PK 0+030

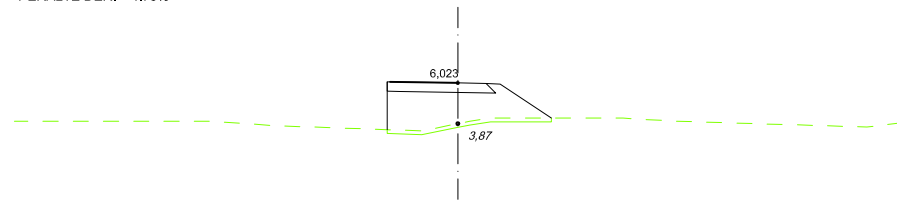

-5

T = 17,73 M2
 D = 0,00 M2
 Tv= 1,99 M2
 PERALTE IZQ.= -0,13%
 PERALTE DER.= -0,13%

PK 0+020

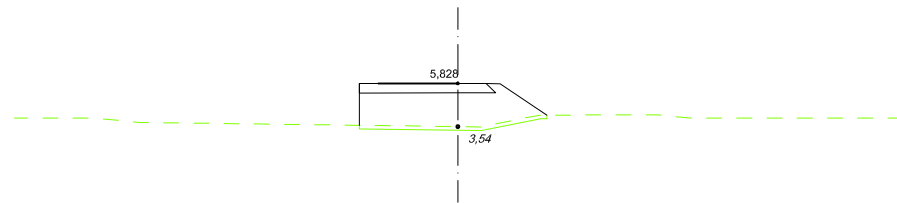

-5

T = 17,95 M2
 D = 0,00 M2
 Tv= 2,14 M2
 PERALTE IZQ.= -1,99%
 PERALTE DER.= -1,99%

PK 0+010

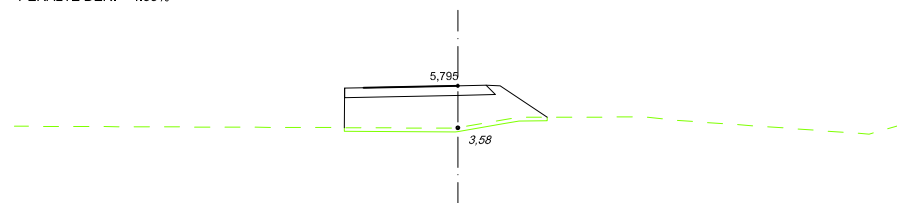

-5

T = 6,44 M2
 D = 0,00 M2
 Tv= 0,98 M2
 PERALTE IZQ.= -0,18%
 PERALTE DER.= -0,18%

PK 0+000

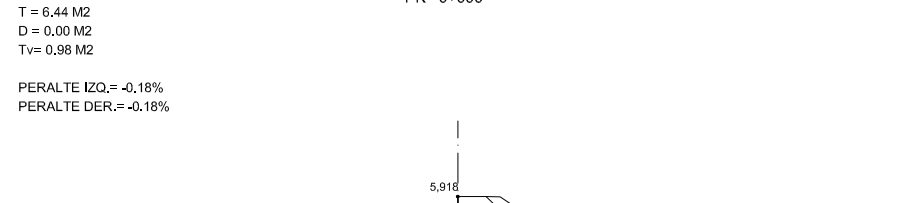

-5

T = 14,16 M2
 D = 0,00 M2
 Tv= 1,70 M2
 PERALTE IZQ.= 2,00%
 PERALTE DER.= 2,00%

PK 0+031,469

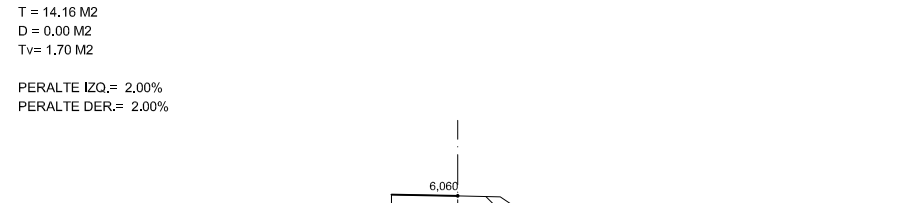

-5

T = 8,12 M2
 D = 0,00 M2
 Tv= 1,29 M2
 PERALTE IZQ.= 2,00%
 PERALTE DER.= 2,00%

PK 0+030

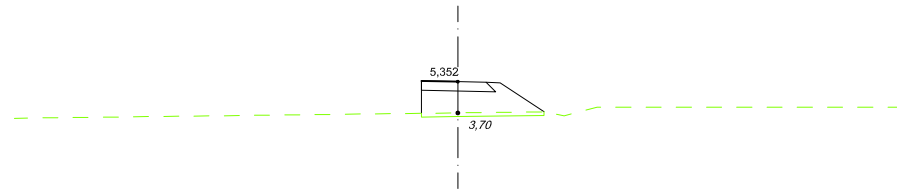

-5

T = 14,39 M2
 D = 0,00 M2
 Tv= 1,94 M2
 PERALTE IZQ.= 2,00%
 PERALTE DER.= 2,00%

PK 0+020

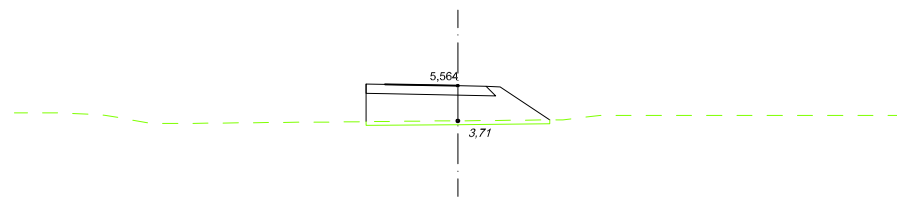

-5

T = 16,04 M2
 D = 0,00 M2
 Tv= 1,90 M2
 PERALTE IZQ.= 2,00%
 PERALTE DER.= 2,00%

PK 0+010

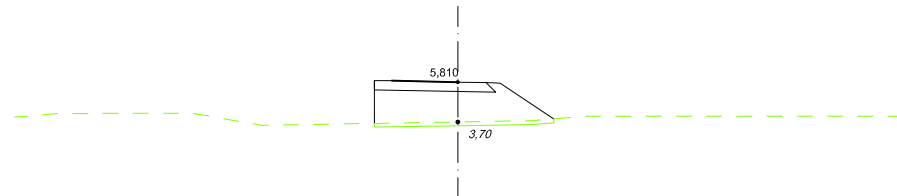

-5

T = 16,52 M2
 D = 0,00 M2
 Tv= 1,76 M2
 PERALTE IZQ.= 2,00%
 PERALTE DER.= 2,00%

PK 0+000

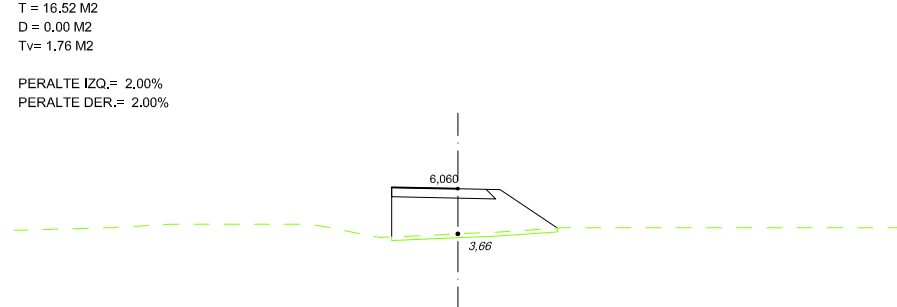

-5

T = 4,96 M2
 D = 0,00 M2
 Tv= 0,86 M2
 PERALTE IZQ.= 2,00%
 PERALTE DER.= 2,00%

PK 0+034,086

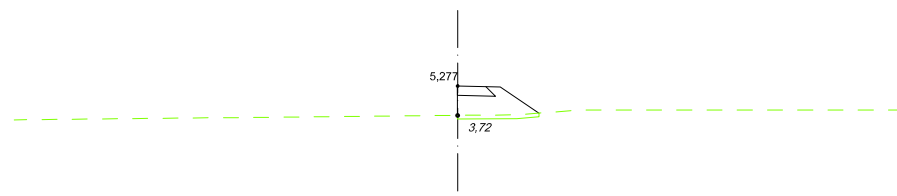

-5

T = 3,09 M2
 D = 0,00 M2
 Tv = 2,49 M2
 PERALTE IZQ.= 2,00%
 PERALTE DER.= 2,00%

PK 0+030

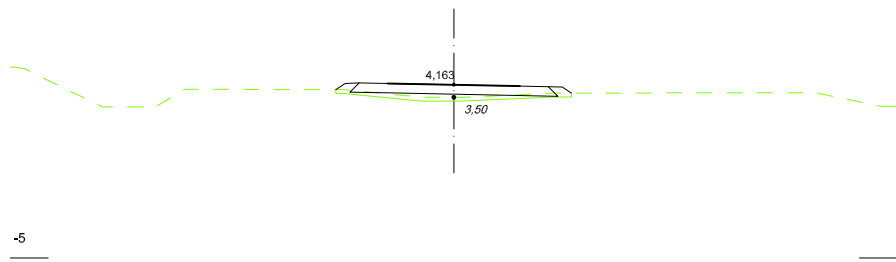

T = 8,90 M2
 D = 0,00 M2
 Tv = 2,82 M2
 PERALTE IZQ.= 0,68%
 PERALTE DER.= 0,68%

PK 0+020

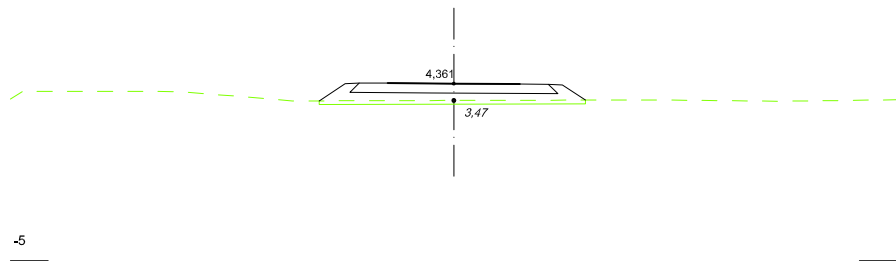

T = 2,04 M2
 D = 3,10 M2
 Tv = 2,74 M2
 PERALTE IZQ.= 2,00%
 PERALTE DER.= 2,00%

PK 0+052,727

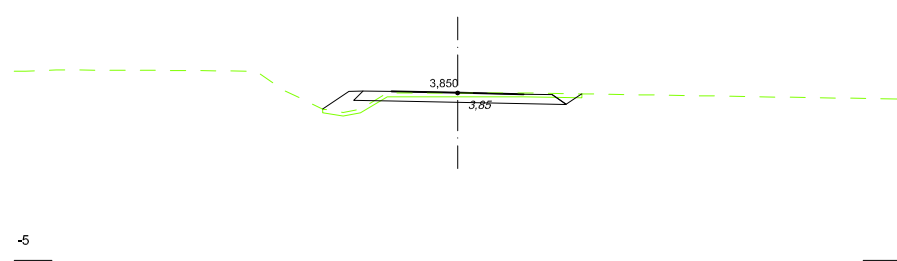

T = 10,78 M2
 D = 0,00 M2
 Tv = 2,89 M2
 PERALTE IZQ.= 0,00%
 PERALTE DER.= -0,66%

PK 0+010

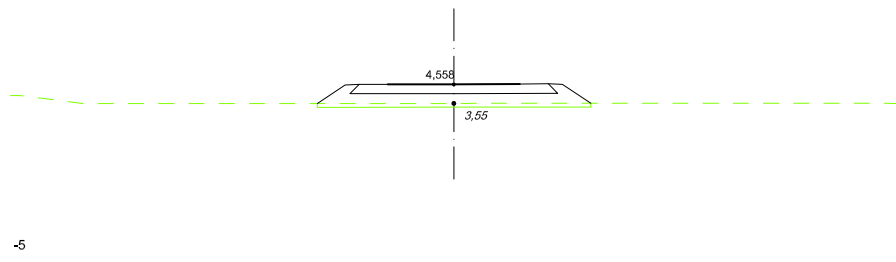

T = 2,01 M2
 D = 2,99 M2
 Tv = 2,74 M2
 PERALTE IZQ.= 2,00%
 PERALTE DER.= 2,00%

PK 0+050

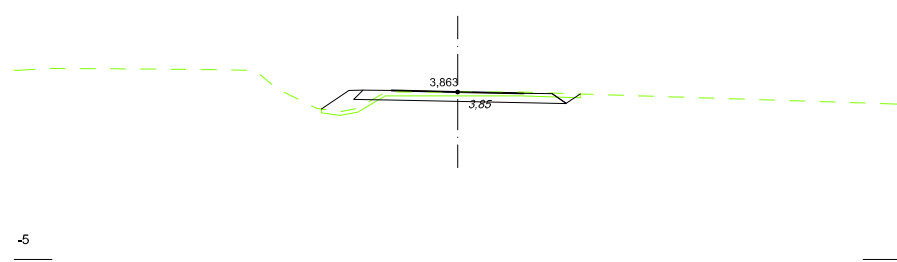

T = 13,45 M2
 D = 0,00 M2
 Tv = 3,00 M2
 PERALTE IZQ.= 0,00%
 PERALTE DER.= -2,00%

PK 0+000

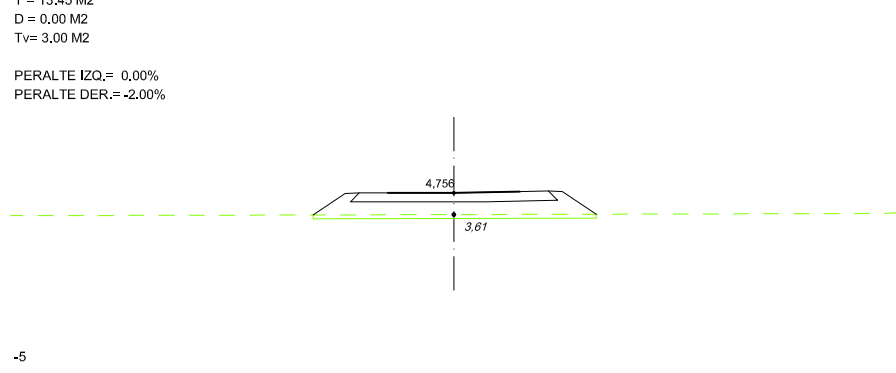

T = 0,52 M2
 D = 1,95 M2
 Tv = 2,37 M2
 PERALTE IZQ.= 2,00%
 PERALTE DER.= 2,00%

PK 0+040

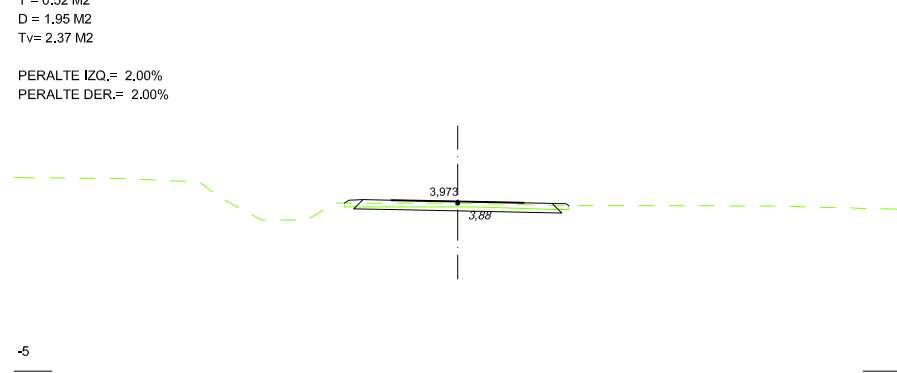

T = 10,42 M2
 D = 0,00 M2
 Tv= 1,71 M2
 PERALTE IZQ.= 2,00%
 PERALTE DER.= 2,00%

PK 0+030

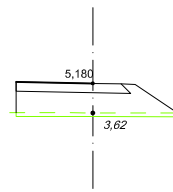

-5

T = 8,39 M2
 D = 0,00 M2
 Tv= 1,63 M2
 PERALTE IZQ.= 2,00%
 PERALTE DER.= 2,00%

PK 0+020

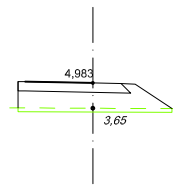

-5

T = 6,48 M2
 D = 0,00 M2
 Tv= 1,48 M2
 PERALTE IZQ.= 2,00%
 PERALTE DER.= 2,00%

PK 0+010

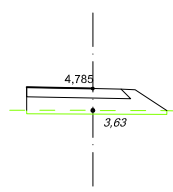

-5

T = 5,91 M2
 D = 0,00 M2
 Tv= 1,46 M2
 PERALTE IZQ.= 2,00%
 PERALTE DER.= 2,00%

PK 0+005

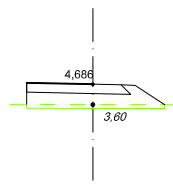

-5

T = 6,60 M2
 D = 0,00 M2
 Tv= 0,99 M2
 PERALTE IZQ.= 2,00%
 PERALTE DER.= 2,00%

PK 0+037,124

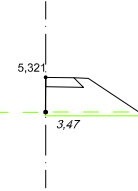

-5

T = 7,48 M2
 D = 0,00 M2
 Tv= 1,51 M2
 PERALTE IZQ.= 1,71%
 PERALTE DER.= 1,71%

PK 0+090

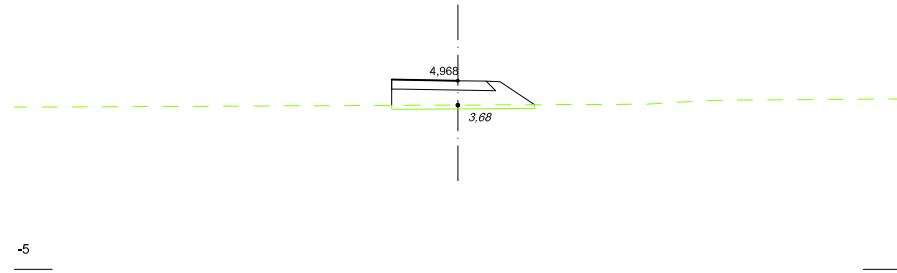

T = 9,62 M2
 D = 0,00 M2
 Tv= 1,85 M2
 PERALTE IZQ.= 2,00%
 PERALTE DER.= 2,00%

PK 0+080

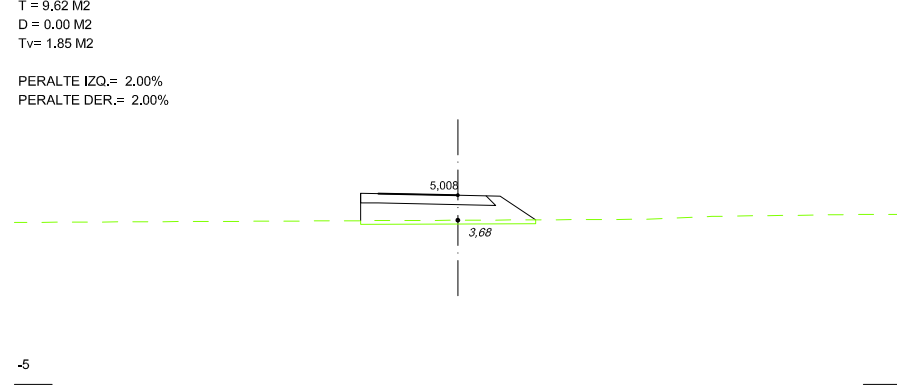

T = 8,35 M2
 D = 0,00 M2
 Tv= 1,60 M2
 PERALTE IZQ.= 2,00%
 PERALTE DER.= 2,00%

PK 0+070

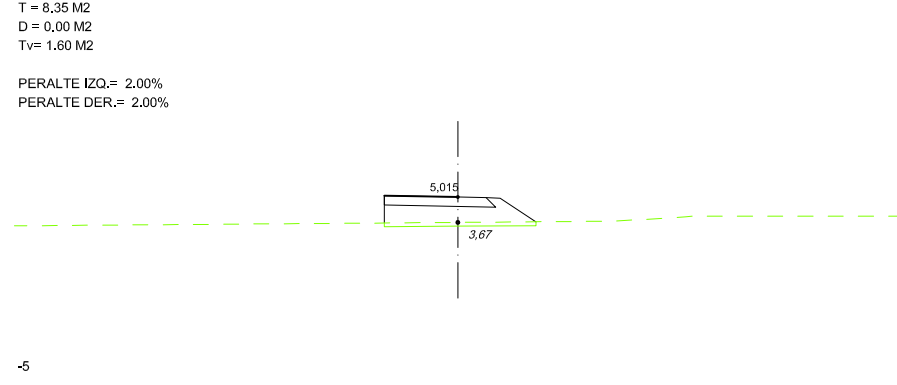

T = 6,27 M2
 D = 0,00 M2
 Tv= 1,48 M2
 PERALTE IZQ.= 0,00%
 PERALTE DER.= 0,00%

PK 0+104,785

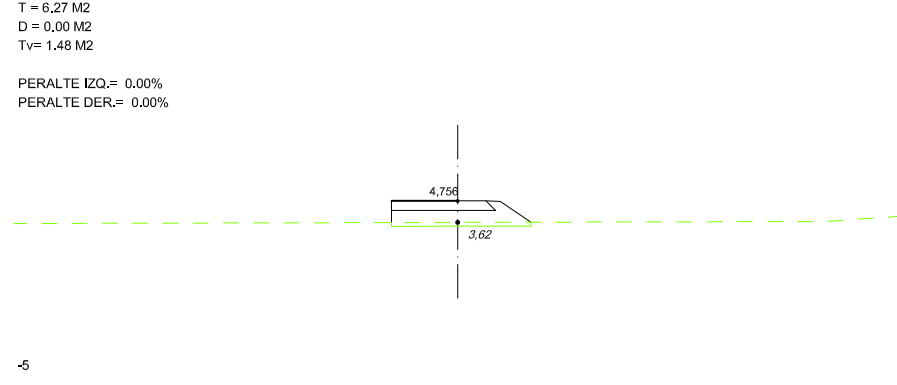

T = 4,00 M2
 D = 0,00 M2
 Tv= 0,82 M2
 PERALTE IZQ.= 2,00%
 PERALTE DER.= 2,00%

PK 0+061,108

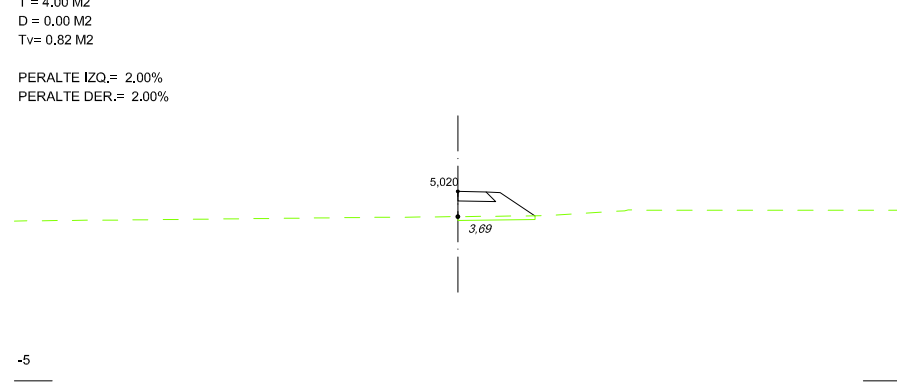

T = 6,77 M2
 D = 0,00 M2
 Tv= 1,49 M2
 PERALTE IZQ.= 0,55%
 PERALTE DER.= 0,55%

PK 0+100

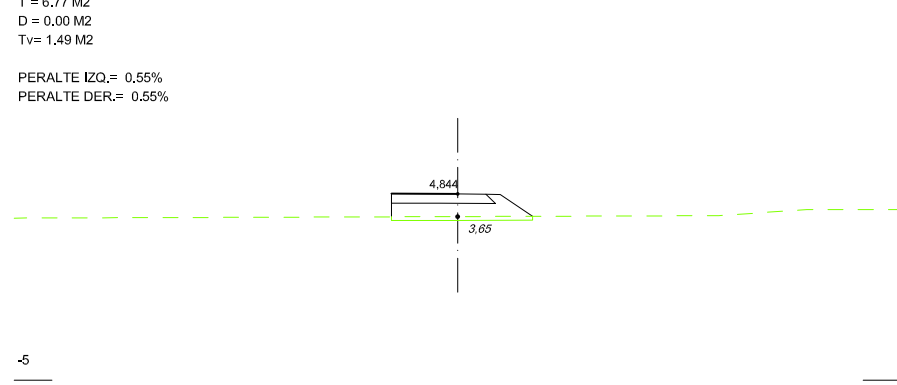

T = 2,05 M2
D = 0,48 M2
Tv = 1,51 M2

PERALTE IZQ.= 2,00%
PERALTE DER.= 2,00%

PK 0+030

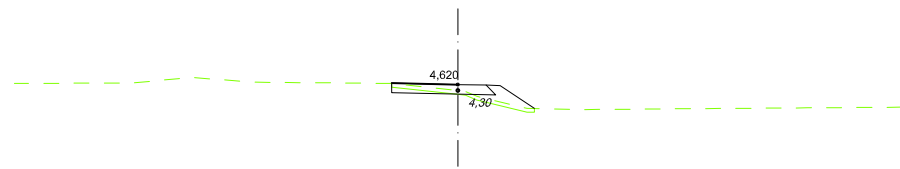

-5

T = 8,60 M2
D = 0,00 M2
Tv = 1,98 M2

PERALTE IZQ.= 3,94%
PERALTE DER.= 3,94%

PK 0+070

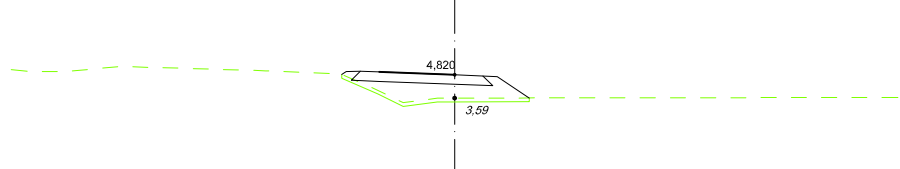

-5

T = 14,51 M2
D = 0,00 M2
Tv = 2,43 M2

PERALTE IZQ.= 2,41%
PERALTE DER.= 2,41%

PK 0+110

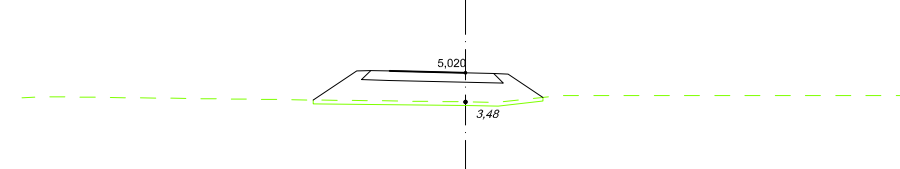

-5

T = 1,99 M2
D = 0,39 M2
Tv = 1,52 M2

PERALTE IZQ.= 2,00%
PERALTE DER.= 2,00%

PK 0+020

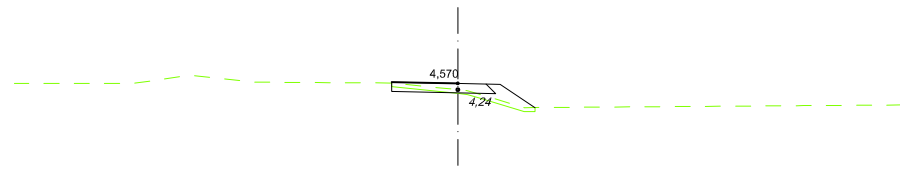

-5

T = 4,66 M2
D = 0,11 M2
Tv = 1,56 M2

PERALTE IZQ.= 3,43%
PERALTE DER.= 3,43%

PK 0+060

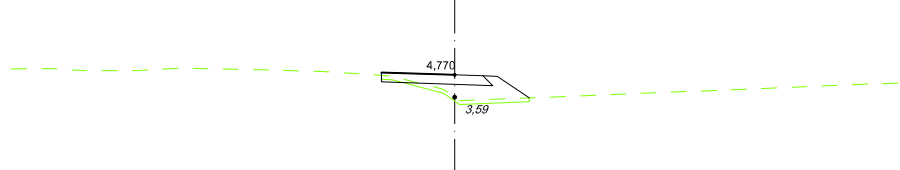

-5

T = 13,06 M2
D = 0,00 M2
Tv = 2,43 M2

PERALTE IZQ.= 3,41%
PERALTE DER.= 3,41%

PK 0+100

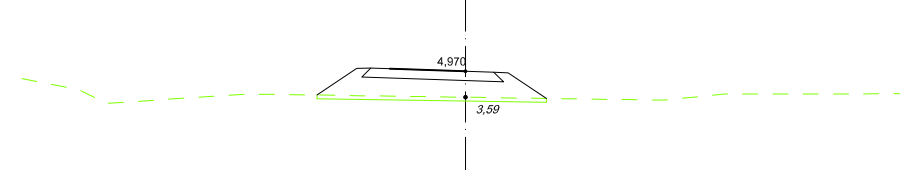

-5

T = 1,83 M2
D = 0,92 M2
Tv = 1,51 M2

PERALTE IZQ.= 2,00%
PERALTE DER.= 2,00%

PK 0+010

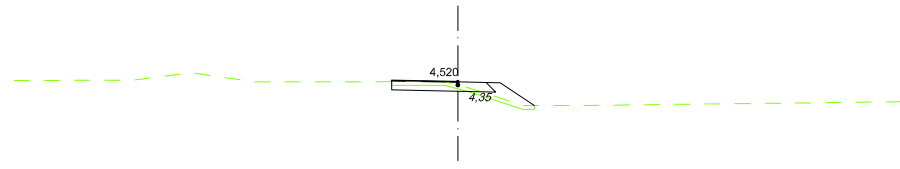

-5

T = 2,92 M2
D = 0,40 M2
Tv = 1,57 M2

PERALTE IZQ.= 2,92%
PERALTE DER.= 2,92%

PK 0+050

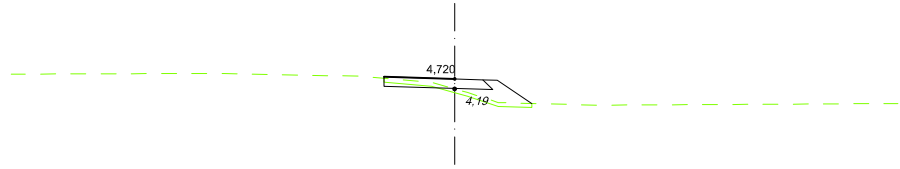

-5

T = 12,07 M2
D = 0,00 M2
Tv = 2,46 M2

PERALTE IZQ.= 4,00%
PERALTE DER.= 4,00%

PK 0+090

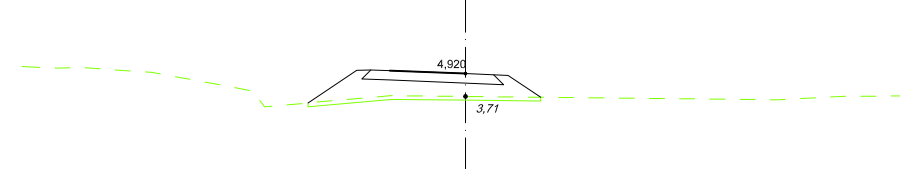

-5

T = 1,28 M2
D = 0,80 M2
Tv = 1,46 M2

PERALTE IZQ.= 2,00%
PERALTE DER.= 2,00%

PK 0+000



-5

T = 2,21 M2
D = 0,52 M2
Tv = 1,53 M2

PERALTE IZQ.= 2,41%
PERALTE DER.= 2,41%

PK 0+040

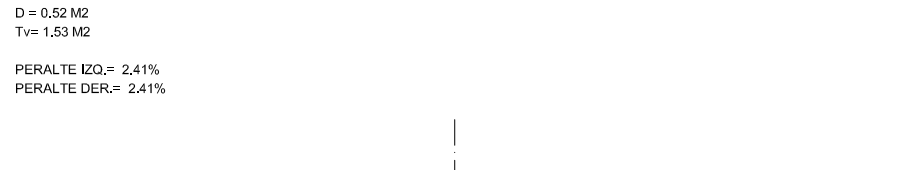

-5

T = 12,16 M2
D = 0,00 M2
Tv = 2,20 M2

PERALTE IZQ.= 4,00%
PERALTE DER.= 4,00%

PK 0+080



-5

T = 12,83 M2
 D = 0,00 M2
 Tv= 2,39 M2
 PERALTE IZQ.= -1,59%
 PERALTE DER.= -1,59%

PK 0+150

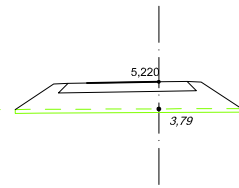

-5

T = 9,36 M2
 D = 0,00 M2
 Tv= 1,61 M2
 PERALTE IZQ.= -0,17%
 PERALTE DER.= -0,17%

PK 0+190

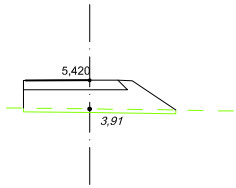

-5

T = 12,93 M2
 D = 0,00 M2
 Tv= 2,41 M2
 PERALTE IZQ.= -0,59%
 PERALTE DER.= -0,59%

PK 0+140

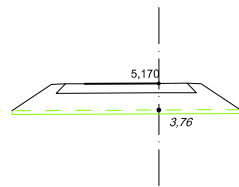

-5

T = 9,77 M2
 D = 0,00 M2
 Tv= 1,75 M2
 PERALTE IZQ.= -1,17%
 PERALTE DER.= -1,17%

PK 0+180

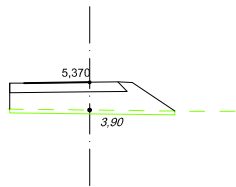

-5

T = 13,57 M2
 D = 0,00 M2
 Tv= 2,45 M2
 PERALTE IZQ.= 0,41%
 PERALTE DER.= 0,41%

PK 0+130

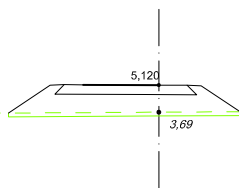

-5

T = 12,24 M2
 D = 0,00 M2
 Tv= 2,35 M2
 PERALTE IZQ.= -2,00%
 PERALTE DER.= -2,00%

PK 0+170

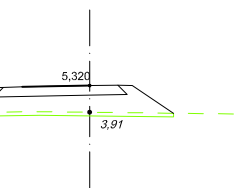

-5

T = 9,66 M2
 D = 0,00 M2
 Tv= 1,60 M2
 PERALTE IZQ.= 2,00%
 PERALTE DER.= 2,00%

PK 0+204,793

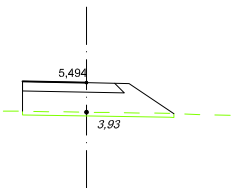

-5

T = 13,55 M2
 D = 0,00 M2
 Tv= 2,46 M2
 PERALTE IZQ.= 1,41%
 PERALTE DER.= 1,41%

PK 0+120

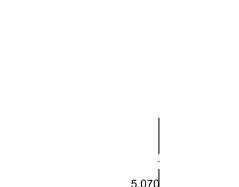

-5

T = 12,25 M2
 D = 0,00 M2
 Tv= 2,35 M2
 PERALTE IZQ.= -2,00%
 PERALTE DER.= -2,00%

PK 0+160



-5

T = 9,52 M2
 D = 0,00 M2
 Tv= 1,59 M2
 PERALTE IZQ.= 1,27%
 PERALTE DER.= 1,27%

PK 0+200

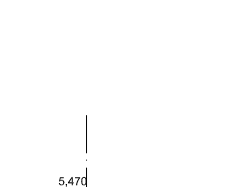

-5

T = 10,88 M2
D = 0,00 M2
Tv = 1,88 M2

PERALTE IZQ.= 4,00%
PERALTE DER.= 4,00%

PK 0+030

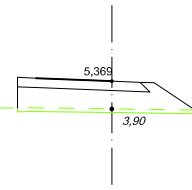

-5

T = 20,22 M2
D = 0,00 M2
Tv = 2,75 M2

PERALTE IZQ.= 4,00%
PERALTE DER.= 4,00%

PK 0+070

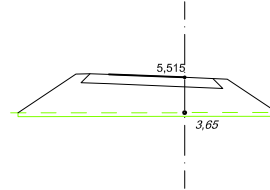

-5

T = 10,98 M2
D = 0,00 M2
Tv = 2,04 M2

PERALTE IZQ.= 4,00%
PERALTE DER.= 4,00%

PK 0+110

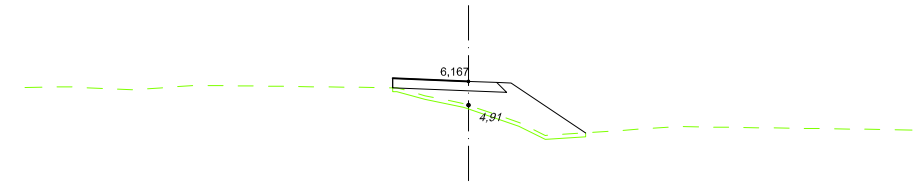

-5

T = 9,70 M2
D = 0,00 M2
Tv = 1,70 M2

PERALTE IZQ.= 4,00%
PERALTE DER.= 4,00%

PK 0+020

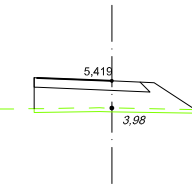

-5

T = 16,99 M2
D = 0,00 M2
Tv = 2,61 M2

PERALTE IZQ.= 4,00%
PERALTE DER.= 4,00%

PK 0+060

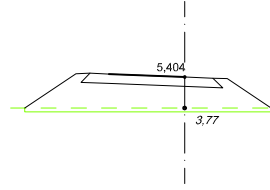

-5

T = 21,43 M2
D = 0,00 M2
Tv = 2,56 M2

PERALTE IZQ.= 4,00%
PERALTE DER.= 4,00%

PK 0+100

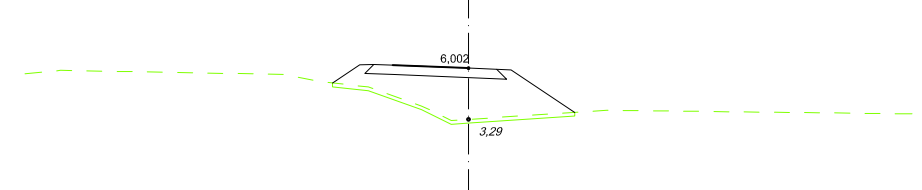

-5

T = 9,19 M2
D = 0,00 M2
Tv = 1,61 M2

PERALTE IZQ.= 2,76%
PERALTE DER.= 2,76%

PK 0+010

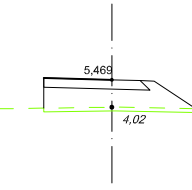

-5

T = 16,39 M2
D = 0,00 M2
Tv = 2,58 M2

PERALTE IZQ.= 4,00%
PERALTE DER.= 4,00%

PK 0+050

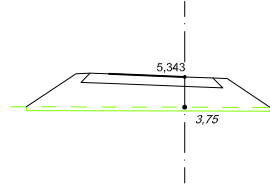

-5

T = 24,83 M2
D = 0,00 M2
Tv = 2,99 M2

PERALTE IZQ.= 4,00%
PERALTE DER.= 4,00%

PK 0+090

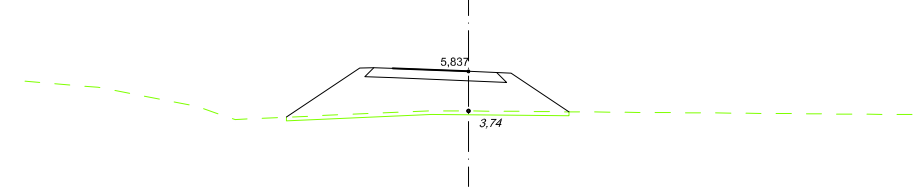

-5

T = 9,02 M2
D = 0,00 M2
Tv = 1,57 M2

PERALTE IZQ.= 2,00%
PERALTE DER.= 2,00%

PK 0+005

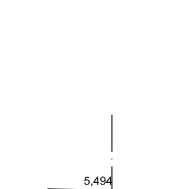

-5

T = 15,32 M2
D = 0,00 M2
Tv = 2,53 M2

PERALTE IZQ.= 4,00%
PERALTE DER.= 4,00%

PK 0+040

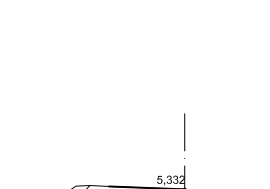

-5

T = 22,73 M2
D = 0,00 M2
Tv = 2,85 M2

PERALTE IZQ.= 4,00%
PERALTE DER.= 4,00%

PK 0+080

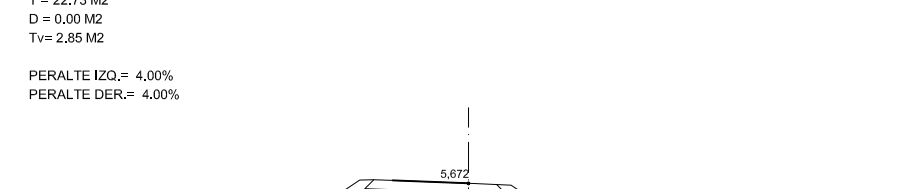

-5

T = 0,00 M2
D = 1,87 M2
Tv = 1,33 M2

PERALTE IZQ.= 2,00%
PERALTE DER.= 2,00%

PK 0+150

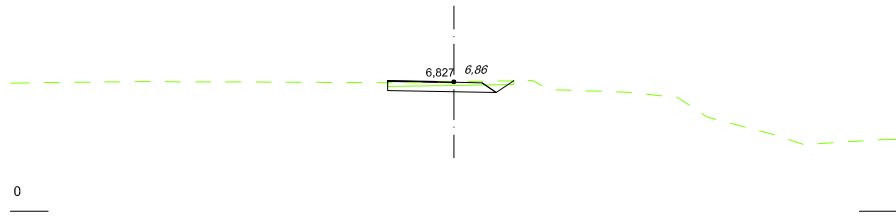

T = 0,60 M2
D = 0,89 M2
Tv = 1,29 M2

PERALTE IZQ.= 2,00%
PERALTE DER.= 2,00%

PK 0+190

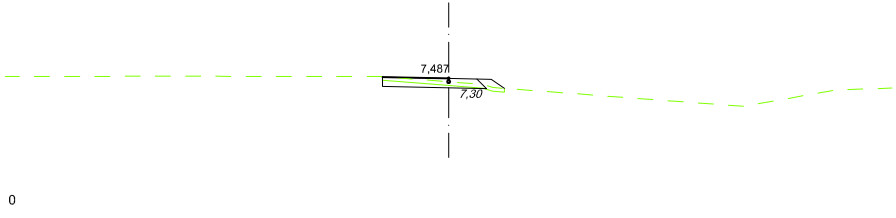

T = 0,47 M2
D = 0,41 M2
Tv = 1,26 M2

PERALTE IZQ.= 2,00%
PERALTE DER.= 2,00%

PK 0+140

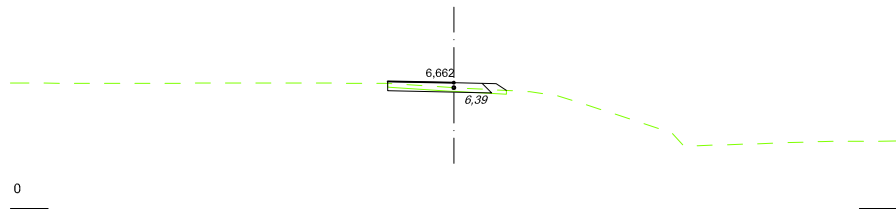

T = 0,64 M2
D = 0,75 M2
Tv = 1,32 M2

PERALTE IZQ.= 2,00%
PERALTE DER.= 2,00%

PK 0+180

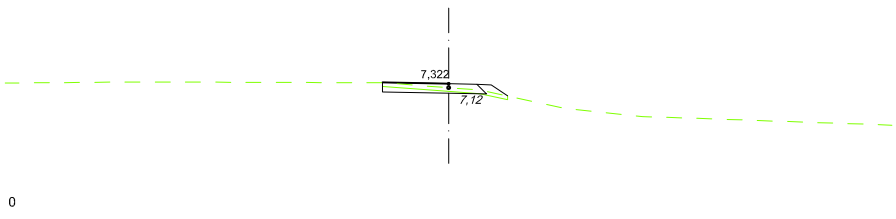

T = 0,29 M2
D = 1,32 M2
Tv = 1,20 M2

PERALTE IZQ.= 2,00%
PERALTE DER.= 2,00%

PK 0+215,425

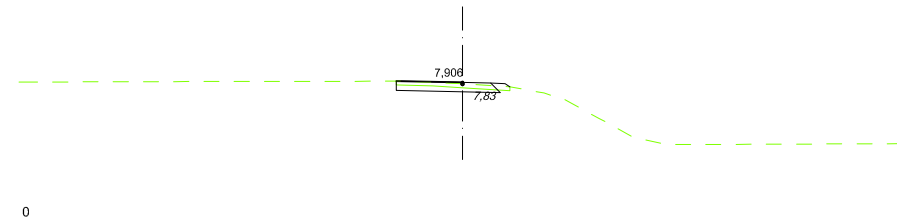

T = 1,42 M2
D = 0,14 M2
Tv = 1,65 M2

PERALTE IZQ.= 2,38%
PERALTE DER.= 2,38%

PK 0+130

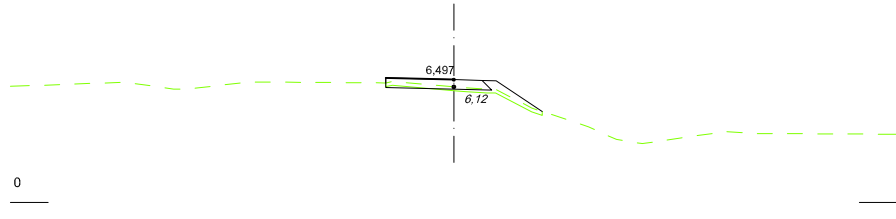

T = 0,59 M2
D = 0,91 M2
Tv = 1,31 M2

PERALTE IZQ.= 2,00%
PERALTE DER.= 2,00%

PK 0+170

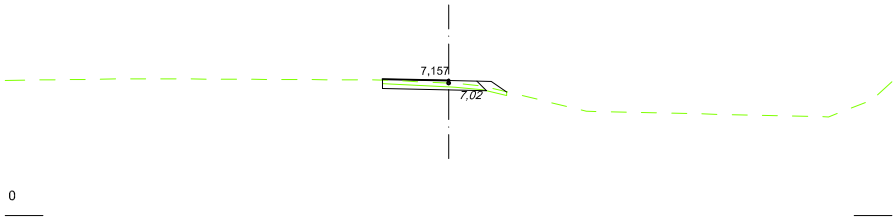

T = 0,16 M2
D = 1,67 M2
Tv = 1,16 M2

PERALTE IZQ.= 2,00%
PERALTE DER.= 2,00%

PK 0+210

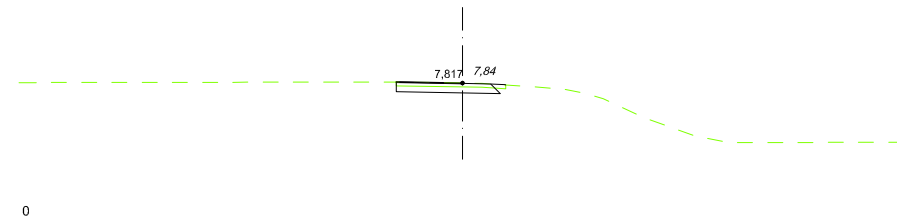

T = 5,38 M2
D = 0,00 M2
Tv = 2,09 M2

PERALTE IZQ.= 3,25%
PERALTE DER.= 3,25%

PK 0+120

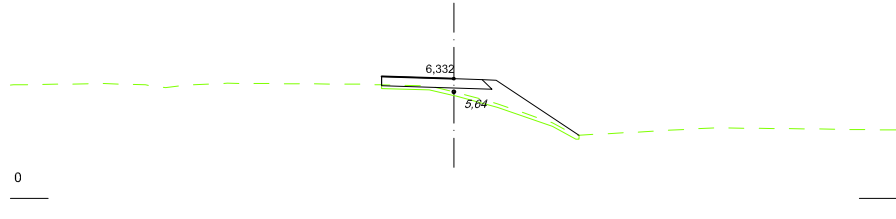

T = 0,52 M2
D = 0,81 M2
Tv = 1,29 M2

PERALTE IZQ.= 2,00%
PERALTE DER.= 2,00%

PK 0+160

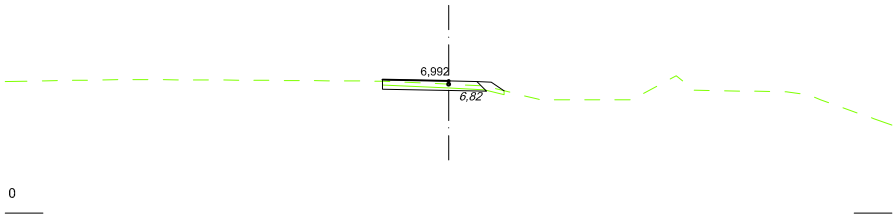

T = 0,00 M2
D = 1,69 M2
Tv = 1,32 M2

PERALTE IZQ.= 2,00%
PERALTE DER.= 2,00%

PK 0+200

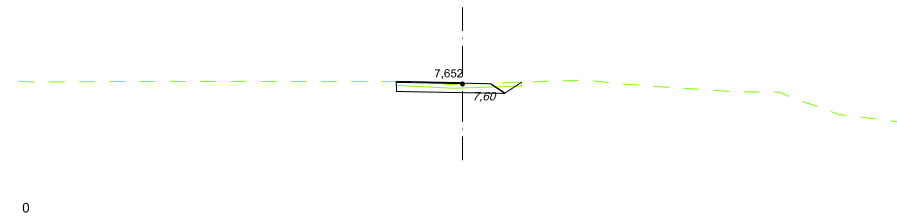

T = 30,52 M2
D = 0,00 M2
Tv = 3,60 M2

PERALTE IZQ.= -2,00%
PERALTE DER.= 2,00%

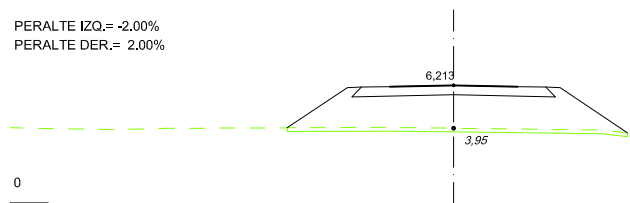

T = 0,50 M2
D = 4,23 M2
Tv = 2,52 M2

PERALTE IZQ.= -2,00%
PERALTE DER.= 2,00%

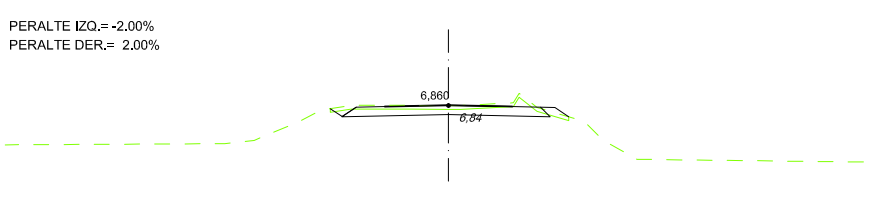

T = 25,69 M2
D = 0,00 M2
Tv = 3,43 M2

PERALTE IZQ.= -2,00%
PERALTE DER.= 2,00%

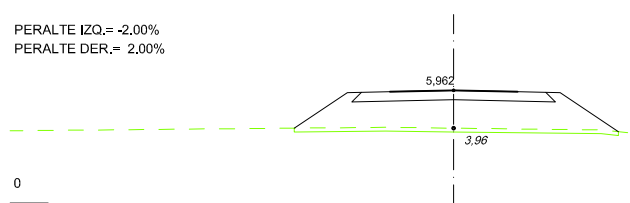

T = 3,11 M2
D = 5,44 M2
Tv = 3,30 M2

PERALTE IZQ.= -2,00%
PERALTE DER.= 2,00%

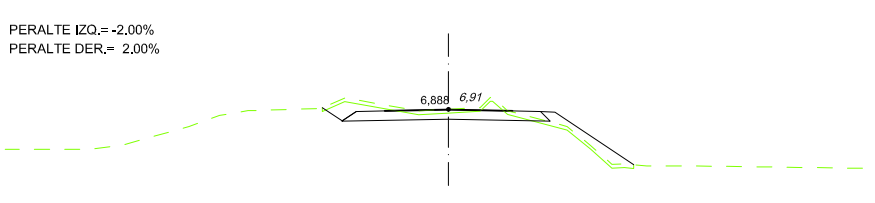

T = 22,12 M2
D = 0,00 M2
Tv = 3,30 M2

PERALTE IZQ.= -2,00%
PERALTE DER.= 2,00%

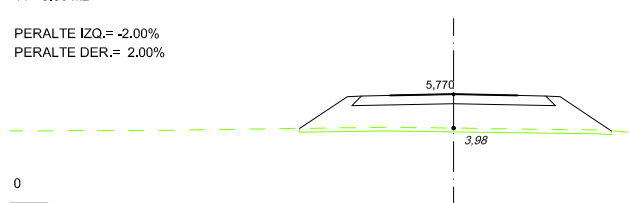

T = 12,75 M2
D = 2,73 M2
Tv = 3,24 M2

PERALTE IZQ.= -2,00%
PERALTE DER.= 2,00%

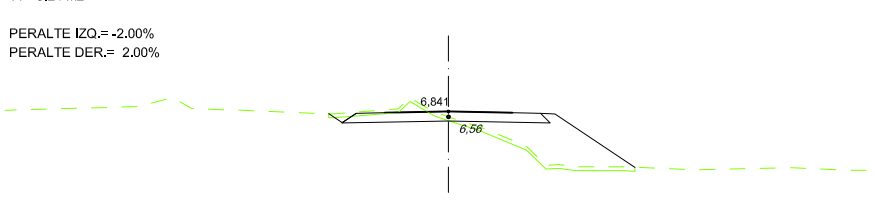

T = 3,91 M2
D = 3,45 M2
Tv = 3,35 M2

PERALTE IZQ.= -2,00%
PERALTE DER.= 2,00%

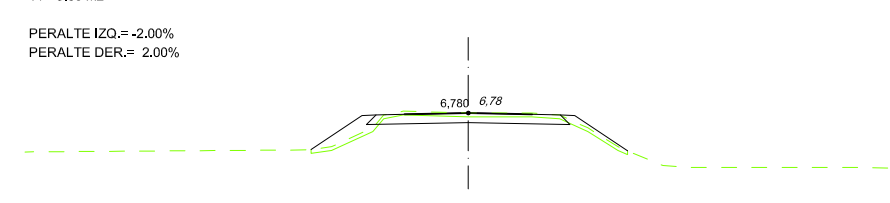

T = 19,77 M2
D = 0,00 M2
Tv = 3,21 M2

PERALTE IZQ.= -2,00%
PERALTE DER.= 2,00%

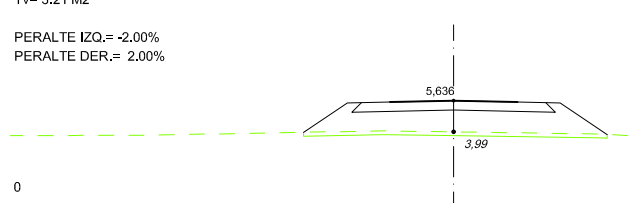

T = 31,73 M2
D = 0,00 M2
Tv = 3,25 M2

PERALTE IZQ.= -2,00%
PERALTE DER.= 2,00%

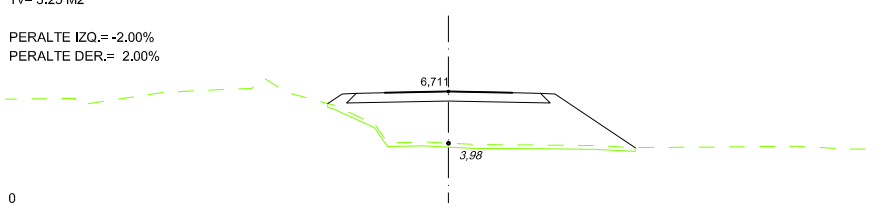

T = 3,91 M2
D = 3,45 M2
Tv = 3,35 M2

PERALTE IZQ.= -2,00%
PERALTE DER.= 2,00%

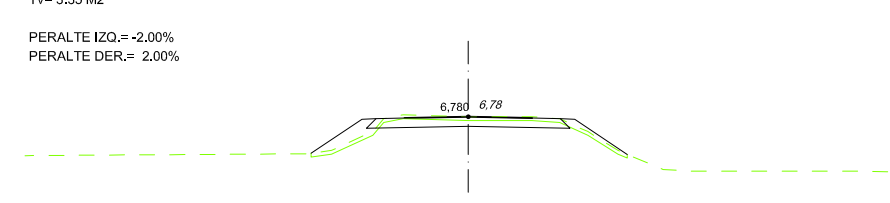

T = 18,68 M2
D = 0,00 M2
Tv = 3,17 M2

PERALTE IZQ.= -2,00%
PERALTE DER.= 2,00%

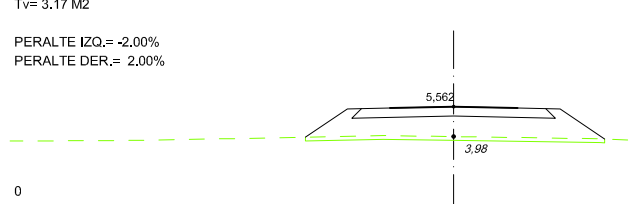

T = 37,38 M2
D = 0,00 M2
Tv = 3,79 M2

PERALTE IZQ.= -2,00%
PERALTE DER.= 2,00%

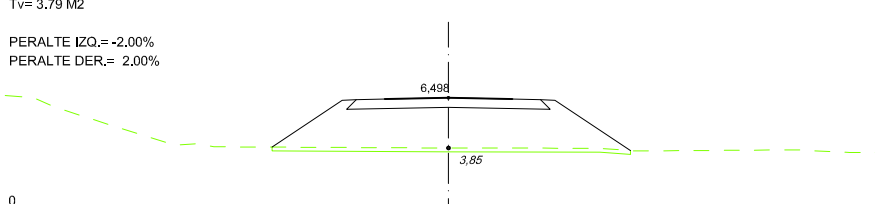

T = 2,82 M2
D = 3,80 M2
Tv = 3,03 M2

PERALTE IZQ.= -2,00%
PERALTE DER.= 2,00%

