

CIAIAC

COMISIÓN DE
INVESTIGACIÓN
DE **A**CCIDENTES
E **I**NCIDENTES DE
AVIACIÓN **C**IVIL

Interim Report A-032/2008

Accident involving aircraft
McDonnell Douglas DC-9-82
(MD-82), registration EC-HFP,
operated by Spanair, at
Madrid-Barajas airport
on 20 August 2008



GOBIERNO
DE ESPAÑA

MINISTERIO
DE FOMENTO

Interim Report

A-032/2008

**Accident involving aircraft McDonnell Douglas
DC-9-82 (MD-82), registration EC-HFP, operated
by Spanair, at Madrid-Barajas airport
on 20 August 2008**



GOBIERNO
DE ESPAÑA

MINISTERIO
DE FOMENTO

SUBSECRETARÍA

COMISIÓN DE INVESTIGACIÓN
DE ACCIDENTES E INCIDENTES
DE AVIACIÓN CIVIL

Edita: Centro de Publicaciones
Secretaría General Técnica
Ministerio de Fomento ©

NIPO:
Depósito legal: M. 23.129-2003
Imprime: Diseño Gráfico AM2000

COMISIÓN DE INVESTIGACIÓN DE ACCIDENTES E INCIDENTES DE AVIACIÓN CIVIL

Tel.: +34 91 597 89 63
Fax: +34 91 463 55 35

E-mail: ciaiac@fomento.es
<http://www.ciaiac.es>

C/ Fruela, 6
28011 Madrid (España)

Foreword

This report is a technical document that reflects the point of view of the Civil Aviation Accident and Incident Investigation Commission (CIAIAC) regarding the circumstances of the event.

In accordance with the provisions of Law 21/2003 and pursuant to Annex 13 of the International Civil Aviation Convention, the investigation is of exclusively a technical nature, and its objective is not the assignment of blame or liability. The investigation was carried out without having necessarily used legal evidence procedures and with no other basic aim than preventing future accidents.

Consequently, any use of this report for purposes other than that of preventing future accidents may lead to erroneous conclusions or interpretations.

This report was originally issued in Spanish. This English translation is provided for information purposes only.

Table of contents

Abbreviations	vii
Data summary	ix
Introduction	1
1. Factual information	3
1.1. History of the flight	3
1.2. Aircraft information	4
1.2.1. General information	4
1.2.2. High-lift devices	4
1.2.2.1. Operation/actuation (see Figure 1)	4
1.2.2.2. Flaps/slats cockpit controls	6
1.2.2.3. Flap and slat position sensors and indicating systems	8
1.2.3. TOWS, take off warning system	9
1.2.4. Ground sensing system. The R2-5 relay	10
1.2.5. Ram Air Temperature probe heater	13
1.2.6. Weight and balance	14
1.2.7. Maintenance history	14
1.2.7.1. Previous indications of excessive RAT probe temperatures on the accident airplane	15
1.3. Flight recorders	17
1.3.1. Recovery of recorded information	18
1.3.2. Information contained on the flight recorders	19
1.4. Inspections, tests and research	23
1.4.1. Flaps/slats	23
1.4.1.1. Inspection of the wreckage at the accident site	23
1.4.1.2. Inspection of flap/slat lever	23
1.4.2. Study of the conditions under which the high RAT probe temperature episodes occurred with the accident airplane on the ground	25
1.4.3. Relay R2-5 on ground sensing system	27
1.4.4. Ground test on similar airplane	28
1.5. Operational procedures	30
1.5.1. Spanair Operations Manual	30
1.5.1.1. General criteria applicable to the checklists	30
1.5.1.2. Before takeoff checklists on the MD-80 series	30
1.5.2. Boeing FCOM	32
1.6. Other information	33
1.6.1. Prior accidents involving inadequate takeoff configurations	33
1.6.1.1. MD-82 Northwest Airlines. Detroit (USA), 1987	33
1.6.1.2. B727 Delta Airlines. Dallas-Fort Worth (USA), 1988	34
1.6.1.3. B737 Mandala Airlines. Medan (Indonesia), 2005	34
1.6.1.4. Incidents reported to the NASA ASRS system	35
1.6.2. Previous incidents involving high RAT probe temperature indications on the ground	36

- 1.6.2.1. Cases compiled by Boeing 36
 - 1.6.2.2. Cases reported by Spanair 36
 - 1.6.2.3. Cases reported by other operators 37
 - 1.6.3. Prior faults during pre-flight check of the TOWS 38
 - 1.6.4. Measures taken 38
 - 1.6.4.1. Airworthiness directive issued by the EASA 38
 - 1.6.4.2. Safety alert issued by the FAA 38
 - 1.6.4.3. Modifications to operational procedures made by Spanair 39
 - 1.6.4.4. Modifications made to Operations Manual by Boeing 39
- 2. Discussion** 41
 - 2.1. Check of TOWS prior to takeoff 42
 - 2.2. The R2-5 relay of the ground sensing system and the TOWS 44
 - 2.3. Considerations on the criticality and reliability of takeoff warning systems in the MD-80 generation of airplanes 48
 - 2.4. Certification of critical systems 52
 - 2.5. Operational procedures and checklists 53
- 3. Status of the investigation** 59
- Appendices** 61
 - Appendix 1. Graphs of DFDR parameters 63
 - Appendix 2. EASA Airworthiness Directive AD no. 2008-0197. SAFO no. 08021 FAA 69
 - Appendix 3. Safety Recommendation REC 01/09 75

Abbreviations

00 °C	Degrees centigrade
AAIB	Air Accident Investigation Branch – Official aviation accident investigation agency of the United Kingdom
AC	Advisory Circular – notice issued by the FAA of the United States
ACAS	Airborne Collision Alerting System
AESA	Spain’s State Agency for Aviation Safety
AFM	Aircraft Flight Manual
AMC	Acceptable Means of Compliance
AMM	Aircraft Maintenance Manual
AOL	All Operators Letter
APU	Auxiliary Power Unit
ASRS	Aviation Safety Reporting System
ATLB	Aircraft Technical Log Book
ATC	Air Traffic Control
ATOW	Actual Takeoff Weight
ATPL(A)	Airline Transport Pilot
BITE	Built-In Test Equipment
CAS	Calibrated Air Speed
CAWS	Central Aural Warning System
CGA	Centro de Gestión Aeroportuaria (Airport Management Center)
CIAIAC	Comisión de Investigación de Accidentes e Incidentes de Aviación Civil (Spain’s Civil Aviation Accident and Incident Investigation Commission)
CPL(A)	Commercial Pilot
CVR	Cockpit Voice Recorder
DFDR	Digital Flight Data Recorder
DFGC	Digital Flight Guidance Computer
DOW	Dry Operation Weight
DGAC	Dirección General de Aviación Civil (Spain’s Civil Aviation Authority)
EASA	European Aviation Safety Agency
EDG	Engine-Driven Generator
EGPWS	Enhanced Ground Proximity Warning System
EOAP	Engine Overhead Annunciator Panel
EPR	Engine Pressure Ratio
FAA	Federal Aviation Administration
FC	Flight Cycle
FCOM	Flight Crew Operations Manual
FDAU	Flight Data Acquisition Unit
FH	Flight Hours
GND	Ground
GPWS	Ground Proximity Warning System
h	Hour(s)
Ha	Hectare(s)
Hz	Hertz
ILS	Instrumental Landing System
INTA	Instituto Nacional de Técnica Aeroespacial (National Aerospace Technology Institute)
IRU	Inertial Reference Unit
JAA	Joint Aviation Authorities
kt	Knot(s)
LCD	Liquid Crystal Display
L/P	Left Pilot
MAC	Mean Aerodynamic Chord
MAD	IATA code for Madrid-Barajas airport
MEL	Minimum Equipment List
METAR	Aviation routine weather report
MMEL	Master Minimum Equipment List
MRBR	Maintenance Review Board Report

Abbreviations

MTOW	Maximum Take Off Weight
NTSB	National Transport Safety Board – Official aviation accident investigation agency of the United States of America
NTS	National Transport Safety Committee – Official transportation accident investigation agency of Indonesia
PF	Pilot Flying
PNF	Pilot Not Flying
POI	Principal Operator Inspector
PSEU	Proximity Switch Electronic Unit
P/N	Part Number
QAR	Quick Access Recorder
QNH	Atmospheric Pressure (Q) at Nautical Height
RAT	Ram Air Temperature
RH	Right hand
RP	Right Pilot
SAFO	Safety Alert for Operators
SDP	System Display Panel
SOP	Standard Operating Procedures
TAT	Total Air Temperature
TM1(2) (3)	Maintenance technician number 1(2) (3)
TOWS	Takeoff Warning System
TRI	Thrust Rating Indicator
TRP	Thrust Rating Panel
TRS	Thrust Rating System
UTC	Coordinated Universal Time
V	Volts
WDM	Wiring Diagram Manual
WOW	Weight on Wheels

DATA SUMMARY

LOCATION

Date and time	Wednesday, 20 August 2008; 14:24 local time¹
Site	Madrid-Barajas Airport. Madrid (Spain)

AIRCRAFT

Registration	EC-HFP
Type and model	McDONNELL DOUGLAS DC-9-82 (MD-82)
Operator	Spanair

Motores

Type and model	PRATT & WHITNEY JT8D-219
Number	2

CREW

	Pilot in command	Copilot
Age	39 years old	31 years old
License	Airline Transport Pilot ATPL(A)	Commercial Pilot CPL(A)
Total flying hours	8,476 h²	1,276 h²
Flying hours on the type	5,776 h	1,054 h

INJURIES

	Fatal	Serious	Minor/None
Crew	6		
Passengers	148	18	
Third persons			

DAMAGE

Aircraft	Destroyed
Third parties	45 Ha area of ground burned

FLIGHT DATA

Type of operation	Commercial air transport – Scheduled – Domestic passenger
Phase of flight	Takeoff – Initial climb

INTERIM REPORT

Date of approval	4 August 2009
------------------	----------------------

¹ All times in this report are local, except otherwise indicated. To obtain UTC, subtract two hours from local time.

² As of 31 July 2008.

INTRODUCTION

This report constitutes the interim report mentioned in paragraph 6.6 of Annex 13 to the Convention on International Civil Aviation. The report is issued as a continuation of the preliminary report published on 8 October 2008. The report includes details on the progress of the investigation and the most salient operational safety issues that have emerged to date. The information provided is subject to change as the investigation progresses.

The Civil Aviation Accident and Incident Investigation Commission (CIAIAC) was notified of the accident at 14:43 on 20 August 2008 by way of a telephone call placed from the Barajas Airport Operations Center. A team consisting of six investigators and the President of the Commission immediately proceeded to Barajas.

In keeping with international agreements, the NTSB³ of the United States of America was notified as the representative of the State of the aircraft's design and manufacture, as were national civil aviation authorities and the European Aviation Safety Agency. The NTSB appointed an accredited representative to take part in the investigation, assisted by experts from the NTSB, the FAA⁴, Boeing, as successor of the rights and obligations of the original aircraft manufacturer, and Pratt & Whitney, the engine manufacturer. Spanair, the operator of the aircraft, is cooperating with the investigation by supplying experts in operations, airworthiness and maintenance. Spain's DGAC, the Agencia Estatal de Seguridad Aérea⁵ (State Agency for Aviation Safety), and the European Aviation Safety Agency are also being informed of the more important aspects of the investigation.

³ The National Transportation Safety Board (NTSB) is the official investigative body for transportation accidents in the United States of America.

⁴ The FAA, Federal Aviation Administration, is the civil aviation authority in the United States of America.

⁵ The Dirección General de Aviación Civil (DGAC) and the Agencia Estatal de Seguridad Aérea jointly comprise Spain's civil aviation authority.

1. FACTUAL INFORMATION

1.1. History of the flight

On 20 August 2008, the McDonnell Douglas DC-9-82 (MD-82) aircraft, registration EC-HFP, operated by Spanair, flew in the early morning from Barcelona to Madrid in what was the first leg scheduled for that day. It departed Barcelona at 08:55 and arrived in Madrid at 10:13. The flight proceeded normally and no incidents were reported.

The aircraft was then scheduled to continue on to Las Palmas with the same flight crew that had flown the previous leg on what was to have been scheduled flight JKK5022, a passenger transport flight from Madrid-Barajas airport to Gran Canaria airport, located on the island of the same name. The estimated departure time was 13:00.

Once cleared by the control tower, the aircraft proceeded to runway 36L from parking stand T21, which it had occupied on the apron at terminal T2 in Barajas. Upon reaching the head of the runway, the crew reported a problem and informed ATC that they had to exit the runway and return to the stand.

The crew had detected an abnormally high temperature indication of the RAT (Ram Air Temperature) probe, and parked the aircraft in position R11 upon reaching the apron. Assistance from maintenance technicians was requested to solve the problem. After checking the MEL, the mechanic proceeded to open the circuit breaker for the electrical circuit that supplied the heat⁶ (Z-29), rendering it inoperative. Once complete, it was proposed and accepted that the airplane be dispatched.

At 14:08 the aircraft was once again cleared for engine start-up. Following that the crew started to perform the prestart and before start checklists. After starting the engines, the after start checklist was performed, with the flaps/slats item omitted since at that moment the captain told the copilot to request clearance from ATC to taxi to runway 36L. At 14:23 the airplane was situated at the head of runway 36L, at which time it was cleared for takeoff once more.

The length of the takeoff run was approximately 1,950 m. Once airborne, the aircraft reached an altitude of 40 ft above ground before descending and impacting the ground.

The stick shaker and aural stall warnings were recorded on the CVR, beginning just after rotation. During the entire takeoff run and until the end of the CVR recording, no sounds were heard relating to the system warning of an inadequate takeoff configuration (TOWS). During the entire period from engine start-up at parking stand

⁶ The circuit breaker for the RAT probe heater is identified as Z-29 in the central electrical panel, situated in the cockpit behind the LH seat.

R11 to the end of the DFDR recording, the deflection values recorded for the flaps were 0°.

The aircraft was destroyed as a result of the impact with the ground and the subsequent fire. There were 172 people aboard the airplane, 154 of whom perished, including all 6 crewmembers. Eighteen passengers, including three minors, were seriously injured.

1.2. Aircraft information

1.2.1. General information

The McDonnell Douglas DC-9-82 (MD-82) aircraft received FAA type certificate no. A6WE on 29 July 1981. The original certificate holder, McDonnell Douglas, transferred its ownership rights to Boeing on 30 January 1998.

The serial number of the accident aircraft was 53148. Assembly was completed on 1 November 1993, after which it was delivered to Korean Airlines. Since July 1998 it was operated by Spanair under Spanish registration EC-HFP.

1.2.2. High-lift devices

The MD82 is designed with high-lift devices on the wing trailing edges (flaps) and on the leading edges (slats).

Each half-wing has two (2) flap sections: inboard and outboard. Each section is moved by means of two (2) hydraulic actuators. All the sections are mechanically linked together so that the extension and retraction movements are synchronized.

The slats surfaces consist of six (6) airfoil segments on each half-wing, numbered zero (0) to five (5) from the root to the tip. They are operated as a unit. Each segment is supported by rails that move along rollers situated on the leading edge of the wing. There are 15 rails on each half-wing, of which 7 are drive and 8 are idler for support. The extension and retraction motions for the entire assembly are controlled by two hydraulic actuators that turn a stepped pulley or drum, which is connected to a system of cables that act directly on the segments.

1.2.2.1. Operation/actuation (see Figure 1)

The flaps and slats are operated jointly in the cockpit with a single flap/slat lever, situated on the front right of the cockpit's central pedestal.

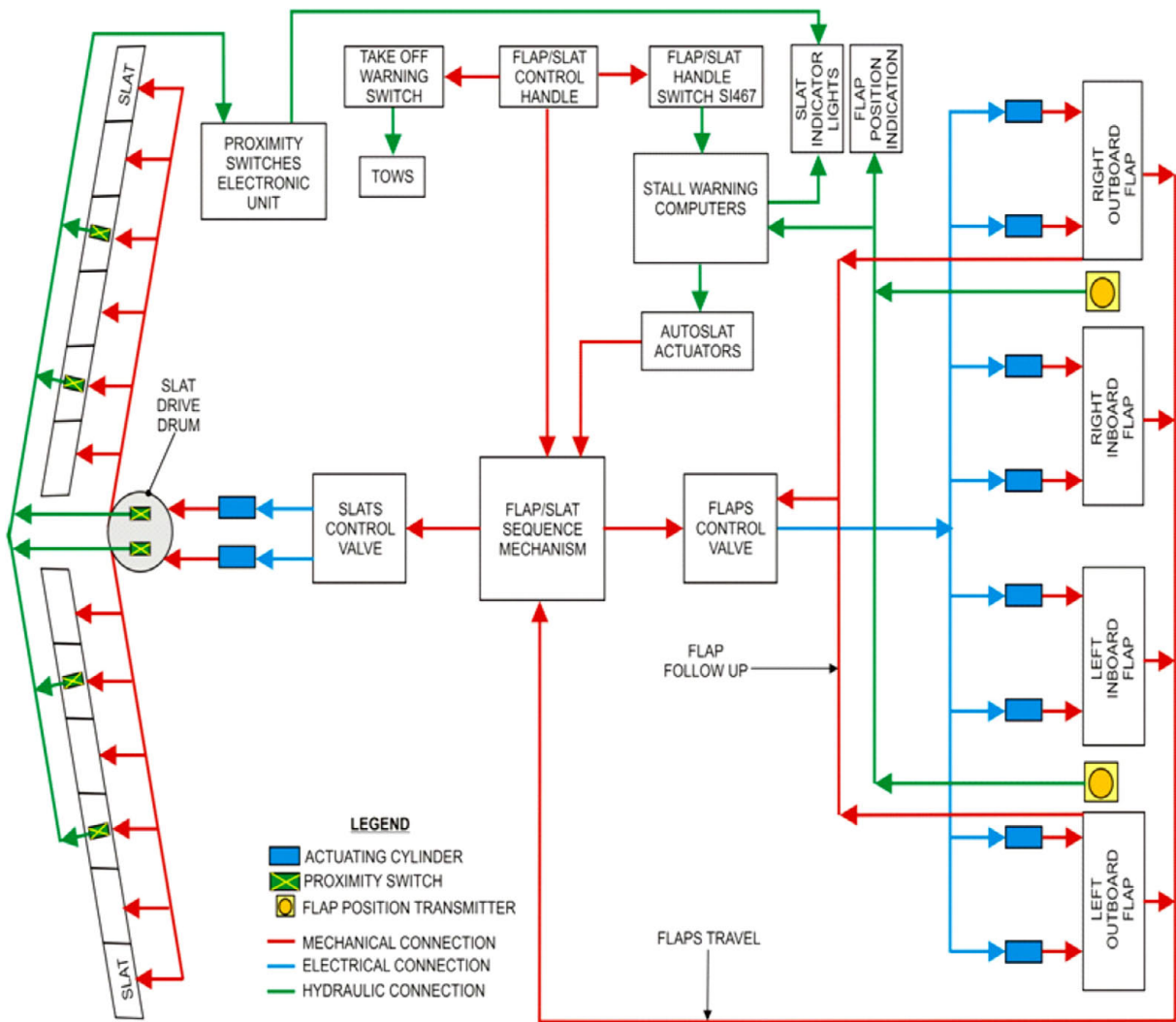

Figure 1. General diagram of flap/slat system

The motion of this lever is transmitted by cables to the flap/slat sequencing mechanism, which is connected by cables to both the flap and slat systems.

The cables corresponding to the flap system are routed to a control valve located in the left wheel well, which is positioned so as to send hydraulic pressure to either extend or retract the flaps, depending on the position commanded by the flap/slat lever.

As they move, the flaps drag a mechanism that ends at the flap control valve, moving it in the direction opposite to that of the cables connecting it to the flap/slat lever, such that the valve closes when the flaps reach the commanded position.

The slats operate in conjunction with the flaps and have three positions: retracted, intermediate and fully extended, depending on the flap selection. Thus, when the flap/slat lever is in the UP/RET position, the slats are retracted. If the flap/slat lever is

placed below 14°, the slats extend to their intermediate position; and with flap/slat lever positions above 14°, the slats are fully extended.

The cables that go to the slat system are routed to another control valve. When the flap/slat lever is moved from the UP/RET position to any other position, the slats start to extend, activating the lever position microswitch (S1-467), inside of which there are five contacts, with two providing a 28V DC signal to the two stall computers. When this microswitch is activated it triggers the BITE automatic test of the number 1 and 2 stall computers, which moves the slats to their maximum extension and then, depending on whether the flap/slat lever is positioned above or below 14°, either maintains the slats fully extended if above 14°, or retracts them to the intermediate position otherwise.

The slats control is mechanical for flap positions between 0° and 13°, inclusive, corresponding to an intermediate slat position, and electromechanical between 15° and 40°, corresponding to a total extension of the slats.

For flap/slat lever positions between 0° and 13° inclusive (slat extension to the intermediate position), the flap/slat lever acts directly on the slat control valve. The extension from intermediate to full is accomplished by means of two electromechanical actuators that receive signals from the stall computer and which actuate the slat control valve.

If, during takeoff, the airplane approaches a stall condition, the computers detect this and automatically send a signal to the electromechanical actuators to fully extend the slats if they are in the intermediate position (Autoslat). Once the condition clears, the stall computers send a signal to the electromechanical actuators to return the slats to their previous position. If the slats are retracted (flap/slat lever in the UP/RET position), the autoslat function is not in effect since the lever position microswitch S1-467 is not activated, meaning the stall computers do not receive the 28V DC signal from the microswitch.

When the control valve is actuated, either mechanically or electromechanically, the valve admits hydraulic pressure to two actuators that turn a double-wheel stepped pulley (drum), which is connected to a system of cables that acts directly on the sliding slat rails.

1.2.2.2. Flaps/slats cockpit controls

Flap/slat control lever (see Figure 2)

The flap/slat lever is situated on the right front part of the pedestal. It moves through a slot with two graduated scales, one on each side. Both scales have markings to indicate the UP/RET, 0, 11, 15, 28 and 40 degree positions. Two additional areas are labeled on the right scale, one between 0° and 24°, which correspond to takeoff values, and another between 24° and 40°, which correspond to landing values.

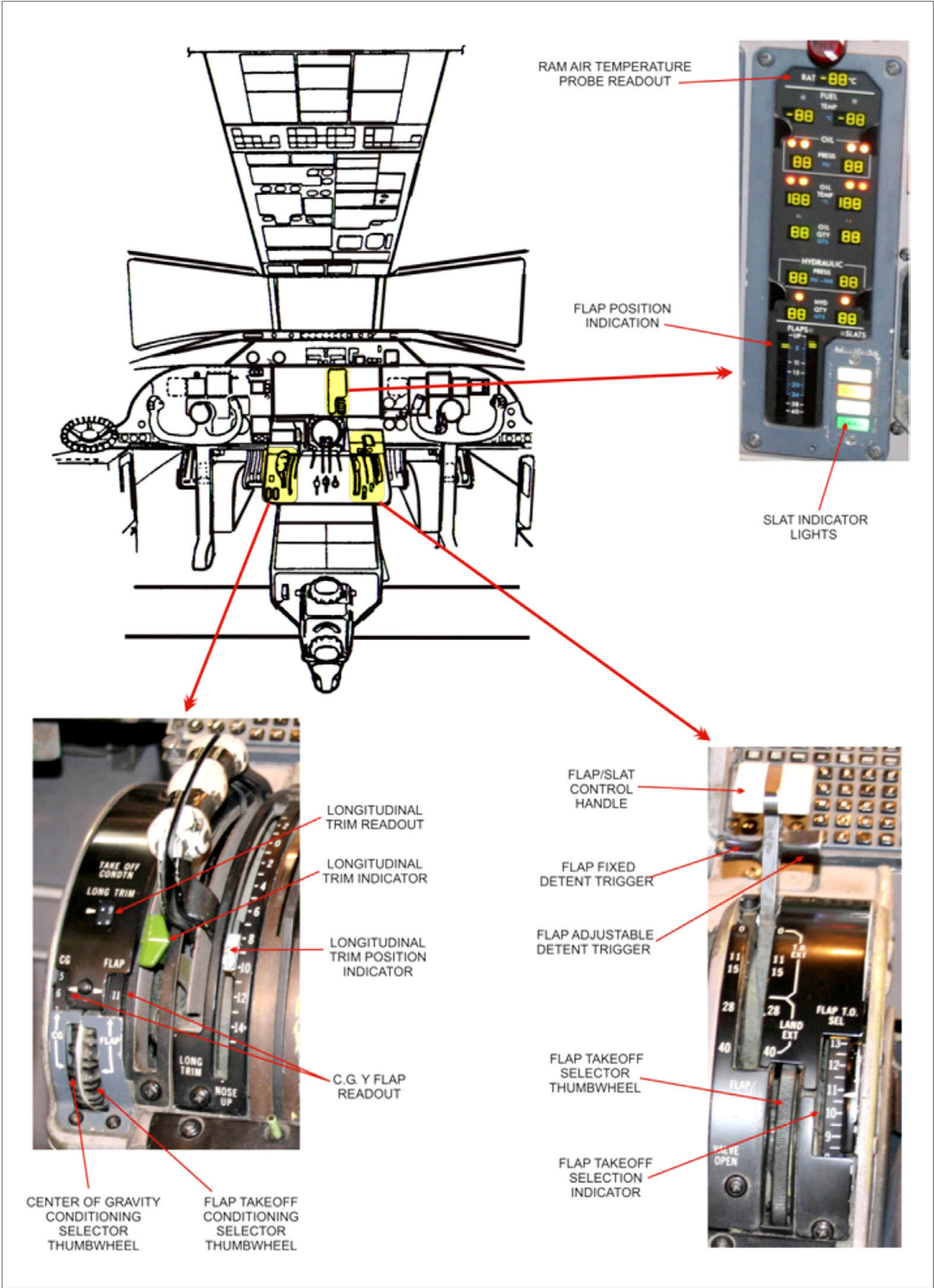

Figure 2. Flap/slat controls and indicators

The lever has two stops, one on each side, that, when lifted against spring pressure, move two stubs located on each side of the lever at the bottom. These are located inside the pedestal, each one housed in a sliding track, both also located inside the pedestal.

The left track is fixed, and has notches for each of the markings on that side's scale (UP, 0, 11, 15, 28 and 40 degrees).

The right track is variable and has a single notch that can be adjusted to any position from 0° to 24° by means of a wheel, with its associated indicator window, situated on the right side of the pedestal. This allows for an exact takeoff flap position to be selected that differs from the fixed positions.

When the flap/slat lever is moved to the selected position, the right stub lodges in that notch, which prevents the lever from being moved unless the right stop is lifted.

Take-off condition – CG/flaps selection/indication panel and longitudinal trim indicator) (see Figure 2)

Located in the aft left part of the central pedestal in the cockpit.

It has a wheel that is used to input the position of the aircraft's center of gravity for that flight in a display window. It features another wheel, also with an associated window, that is used to adjust the value of the flap angle selected by the crew for takeoff.

A mechanical calculator combines both values and, by means of an index and a window, indicates the value of stabilizer trim that the crew should use for takeoff.

Inputting the value for the flap angle as indicated above also moves an axle that reaches across the pedestal to its right side, where it actuates a hinge that positions a flap warning microswitch for takeoff. When the position selected on the flap control lever matches the value input with the wheel on the takeoff condition panel, a cam presses on the microswitch, which then sends a signal to the takeoff warning system (TOWS), indicating that the flap selection is correct, so that the TOWS flap warning is not activated.

1.2.2.3. Flap and slat position sensors and indicating systems

There are two flap position transmitters, one on the left wing and another on the right. They are located in the inboard hinge of each outboard flap and they send their data to the flap position indicator, to the stall computers and to the DFGC.

The flap and slat indicators are located in the right bottom side of the central instrument panel (see Figure 2).

The flap indicator consists of a vertical scale, graduated from UP/RET to 40°, with independent indicators for the LHS and RHS flaps. The indication is provided on a liquid-crystal display (LCD) consisting of two horizontal rows of green lights on each side.

The slat indicator has four lights, T/T, DISAG, AUTO and LAND, colored blue, amber, blue and green, respectively. When lit, these lights indicate the following:

- T/O: flap/slat lever positioned within takeoff range.
- DISAG: the position of the LHS and RHS slats do not agree with each other or are not in the position commanded by the flap/slat lever.
- AUTO: the slats have been automatically extended to their maximum position by the stall warning system.
- LAND: the flaps are extended within the landing range, between 24° and 40°, and the slats are fully extended.

The signal for the T/O, DISAG and LAND lights comes from the proximity sensor electronic unit (PSEU), which receives data on the position of the flap lever from the position microswitch (S1-467). The AUTO light signal is provided directly by the stall computers.

The positions on the slat panels are provided by eight proximity sensors, four on the right side and four on the left. Of the four sensors on each half-wing, two are located in the drum and two are next to the sliding rails for the 1 and 3 slat sections.

1.2.3. *TOWS, take off warning system*

MD-80 series airplanes feature a central aural warning system (CAWS) in the cockpit that provides various audible warnings to the crew when certain potentially unsafe conditions arise or when improper configurations or problems with the operation of certain systems exist.

The TOWS is part of CAWS. The TOWS provides alert warnings on the following components involved in the configuration of the aircraft for takeoff:

- Flaps
- Slats
- Brakes
- Auto brake
- Auto spoilers
- Spoilers
- Stabilizer Trim

The aural warnings consist of an alternating sequence of tones complemented by a synthetic voice to indicate the reason for the warning. Should one or more of these components be improperly configured, the system is designed to provide first the aural warning, followed by the synthetic voice announcement.

The TOWS will issue an aural warning as long as the following conditions exist:

- Airplane on the ground,
- Both throttle levers forward and
- One or more of the following exist:
 1. Slats retracted.
 2. Spoilers extended.
 3. Flaps not in a takeoff configuration or in disagreement with the conditions specified by the takeoff calculator.
 4. Position of horizontal stabilizer disagrees by more than 1.5° with the position set by the takeoff calculator.
 5. The auto brake is not set to the takeoff position with spoilers armed for takeoff.
 6. Spoilers not armed for takeoff with the auto brake selector situated in the takeoff position.
 7. Parking brake not released.

The TOWS is only armed on the ground and is disabled in flight.

1.2.4. *Ground sensing system. The R2-5 relay*

The aircraft has systems that should function only while in flight, only on the ground, or differently if in flight or on the ground. The systems that so require it receive the information that the aircraft is on the ground or in the air through the ground sensing system.

The system consists of three switches located on the nose landing gear that detect whether the aircraft is on the ground or in the air, twenty relays located in the avionics compartment, two circuit breakers located in the cockpit and two 115V AC power supplies (See figure 3).

In the nose landing gear there is a switch that closes if the gear is down and locked (airplane on the ground) and opens otherwise (airplane in flight), and two switches, situated to either side of the first, that close if the strut is compressed, which happens when the airplane is on the ground, and open when the strut is extended, that is, when the airplane is in flight.

The switch of the gear is connected in series with that on the strut's left side. When the airplane is on the ground, both switches close a circuit that supplies eleven (11)

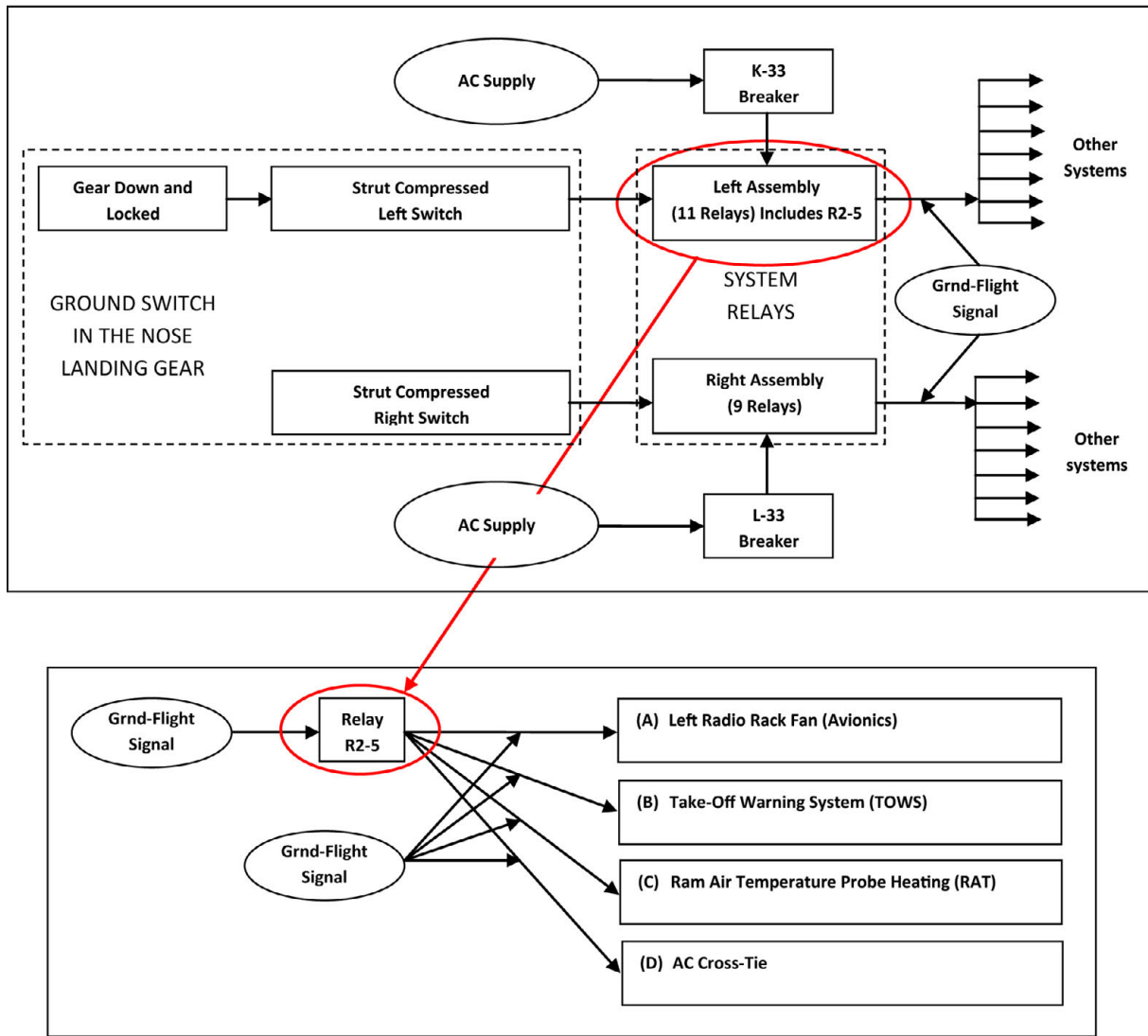

Figure 3. General diagram of the ground sensing system. Relay R2-5

relays, and which makes up the left group of the system. A circuit breaker is present in this circuit, identified as K-33 in the top panel situated behind the LH seat in the cockpit and labeled as “Ground Control Relay Left”.

When the airplane is on the ground, the strut’s right side switch closes to complete a circuit that powers nine (9) relays. This makes up the right side of the system. There is a circuit breaker identified as L-33⁷ on the same panel behind the LH seat in the cockpit and labeled as “Ground Control Relay Right”.

When the airplane is in flight, the nose gear switch and both side strut switches, left and right are open and therefore so are the electrical circuits that power the relays.

⁷ This breaker naming scheme can vary between airplanes.

All the system relays have their coils connected on one side to the power supply via their respective circuit breakers, and on the other to ground through the respective switches on the nose gear.

Each system relay also has four sections with three contacts each, identified as "A", "B", "C" and "D", in each of which the circuit between contact numbers 2 and 3 is closed while in a flight condition and between 2 and 1 while in a ground condition.

The left group of relays includes the R2-5 relay, which transmits the ground-flight mode to the following four systems:

- *Section "A"*: Radio rack ventilation in the avionics compartment, features two fans, left and right, both of which should be running on the ground and only one in flight. The operation of the fans on the ground and in the air is controlled by Section A of relay R2-4. The R2-5 and R2-6 relays, the latter belonging to the right ground-sensing system, are involved in the "Radio Fan Off" indication on the overhead annunciator panel (EOAP).
A 28V DC signal flows through section A of relay R2-5.
- *Section "B"*: Take-off warning system (TOWS), which sounds an aural warning in the cockpit when the aircraft is about to take off in an improper configuration. When the airplane is on the ground with the nose gear strut compressed, both the number 1 and 2 contacts in this section of the relay close to arm the TOWS. When the airplane is in flight, contacts 1 and 2 open and the TOWS is disabled.
A 28V DC signal flows through section B of relay R2-5.
- *Section "C"*: Static ports and probe heaters, consisting of a series of heaters that must be operational when the aircraft is in flight and off when on the ground. The operation of each of these heaters is controlled by various relays. In particular, the operation of the ram air temperature heater is controlled through relay R2-5, which functions when the aircraft is in flight but not on the ground.
A 115V AC signal flows through section C of relay R2-5.
- *Section "D"*: AC cross-tie system, which can distribute AC power to the left and right busses from different sources. With the airplane on the ground, the AC cross-tie is enabled when the power is supplied by the engine-driven generators (EDG) and inhibited when supplied by the auxiliary power unit (APU) or external power. The control of the system is affected by three relays from the ground sensing system: relay R2-309, from the RH relay group and which enables the automatic mode of operation of the system on the ground, and relays R2-5 and R2-8, the latter of which belongs to the RH ground sensing system. Relay R2-5 inhibits cross-tie operation of the left bus on the ground when supplied by the APU or external power.
A 28V DC signal flows through section D of relay R2-5.

1.2.5. *Ram Air Temperature probe heater*

The aircraft has a series of systems that rely on the value of the outside air temperature to ensure they are operating under adequate conditions. This is done by measuring the ram air temperature (RAT) through a probe (RAT probe) that is located on the lower right front part of the fuselage.

So as to keep ice from forming and blocking the probe, the system includes a heater that is designed to be in operation when the aircraft is in flight and disconnected when on the ground.

When the pilot engages the heaters using the rotary switch meter selector and heat, the heater receives AC power from a circuit which includes a circuit breaker that is found in position Z-29 in the lower panel located behind the LH seat in the cockpit and labeled as "Ram Air Temp & Probe Heater". This circuit is completed through the "C" section contacts of relay R2-5 in the left assembly of the ground sensing system, which removes the current when the aircraft is on the ground.

The RAT probe temperature is displayed on the central flight instrument panel, in the top part of the system display panel (SDP). If the system is not working properly and the heater is on with the aircraft on the ground, the probe will measure abnormally high temperatures while on the ground, far above ambient.

AC Power to the Thrust Rating Indicator Panel (TRI), which is part of the thrust Rating System (TRS), is also routed through the same Z-29 circuit breaker. This panel will not

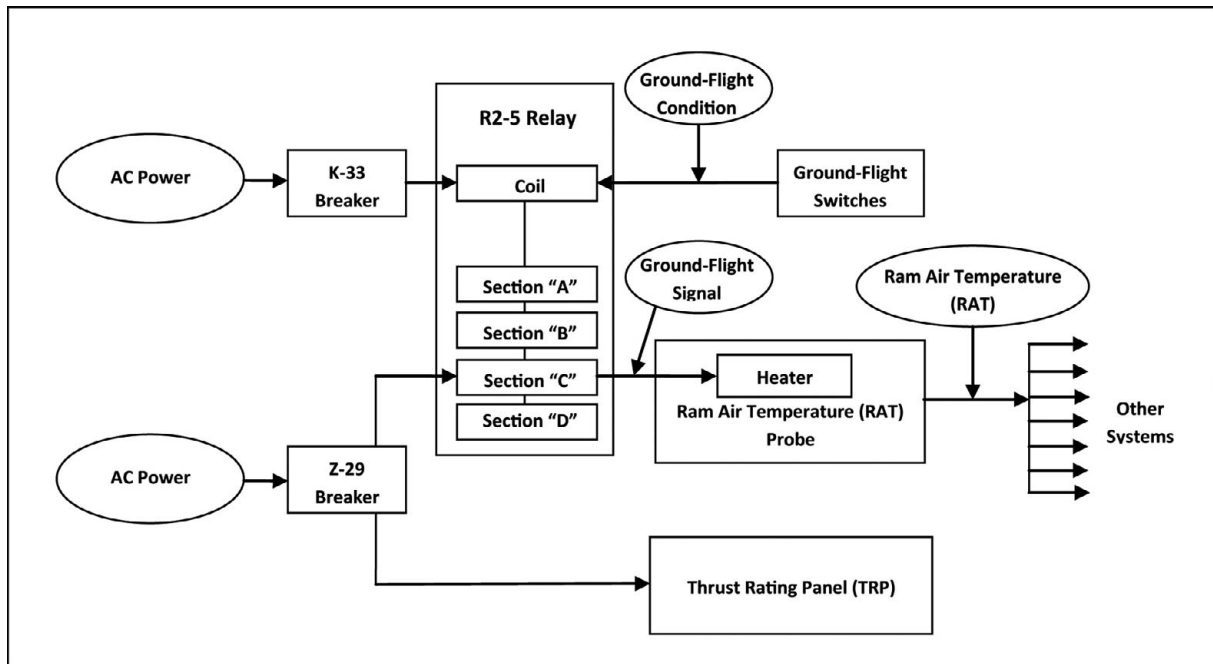

Figure 4. Diagram of the RAT probe heater

function if it does not receive power, as a consequence of which the TRS will be unavailable and the auto throttle will not receive signal from the TRP and so the EPR setting is to be entered manually.

1.2.6. *Weight and balance*

The airplane was refueled at Barajas with 10,130 liters of JET A-1 fuel. The passengers and cargo were then embarked. As noted on the load sheet, the maximum takeoff weight (MTOW) was 147,000 pounds. The total weight of the cargo was 5,190 pounds and that of the passengers 27,655 pounds. Last-minute changes were noted on the load sheet that increased the weight by 555 pounds. The total number of passengers reported on the load sheet was 163, that number being corrected to 166 once the last-minute changes were made.

In all, the aircraft started its first taxi toward the head of runway 36L with an actual takeoff weight (ATOW) of 142,448, distributed as follows:

- Dry operation weight (DOW): 84,318 pounds
- Passengers: 28,210 pounds
- Cargo: 5,190 pounds
- Fuel: 24,730 pounds

The load sheet showed a takeoff center of mass for the aircraft of 8.05% MAC, which was within the approved limits (−0.8% and 26% MAC) specified in chapter 6, Weight and Balance, of the Operations Manual, part B.

According to the load sheet, the fuel burned during taxi was 800 pounds, meaning the aircraft would have had a total weight upon reaching the head of the runway of 141,648 pounds.

Once at the head of the runway, the aircraft returned to the stand to have the malfunction involving the abnormal RAT probe heating fixed. The fuel burned during the taxi was reloaded up to reaching the initial fuel weight of 24,730 pounds, so the second taxi was started once again with 142,448 pounds. The crew did not fill out a new load sheet since the weights were the same as during the first taxi.

The total takeoff weight after the second taxi, therefore, was 141,648 pounds.

1.2.7. *Maintenance history*

Aircraft EC-HFP was maintained in accordance with the MPDM80SP maintenance program, approved on 3 April 2008 by Spain's DGAC in its periodic review TR 05-002.

The MPDM80SP maintenance program is based on the MRBR⁸ of the manufacturer, Boeing, revision 2, issued in November 2003.

The inspection periods and frequencies under this program are:

No.	Inspection Type	Inspection Interval
1	Pre-flight	Before each flight
2	Daily	Every calendar day
3	W	14 calendar days
4	A	120 days
5	C	16 months or 4,500 FH, whichever comes first
6	IV	5 years or 15,500 FH, whichever comes first
7	D	10 years, 30,000 FH or 25,000 FC whichever comes first

The airplane had a total of 31,963 flight hours and 28,133 cycles. It was delivered to the operator on 24 July 1999 with 9,821 total hours and 10,986 total cycles since manufacture. Since that date a total of 33 major inspections (A, C, IV and D) had been conducted in accordance with the approved maintenance program. The last of these inspections (a type A) had been performed on 22 and 23 May 2008, with 31,282 hours and 27,645 cycles on the airplane.

1.2.7.1. Previous indications of excessive RAT probe temperatures on the accident airplane

According to entries in the ATLBs checked, which cover the period between 31 March and 20 August 2008, three unscheduled maintenance tasks were performed in Madrid and Barcelona on 19 and 20 August 2008 by the operator’s maintenance personnel as a result of high flight deck RAT probe temperature indications and logged in the ATLB by the flight crews on those days.

The first of these maintenance actions was carried out at Madrid-Barajas airport on 19 August in response to an entry by the pilots in the ATLB (sequence number 36L): *“During taxi for three times the RAT goes to 90 °C and the corresponding EPR’s below 1.30”*, made during a Barcelona-Madrid flight departing at 15:50.

As he told the CIAIAC, the technician responding to this fault (TM1) noted a cockpit reading for the temperature provided by the RAT probe of 34 °C, which is a normal value for Madrid in the summer. He interpreted this to mean the probe was not being

⁸ Maintenance Review Board report, MSG-3, McDonnell Douglas MD-80, revision 2, issued in November 2003.

heated at that time. He proceeded to disconnect and then re-connect the Z-29 breaker, which provides a path for electricity through the resistance that heats the RAT probe, noting that the temperature reading remained at the same value as indicated above. He then touched the RAT probe to make sure that it was not hot.

He then simulated flight conditions by opening the breakers for the left and right ground sensing system relays (K-33 and L-33, respectively) and energized the RAT probe heater. The probe did in fact become hot, as should be the case under these conditions.

After performing these tasks, he was not able to reproduce the discrepancy noted in sequence 36L by the pilots. As a result of the maintenance action performed, the technician made the following entry in the ATLB at 17:30: *"Reset tested: OK Pls info if fails again"*.

The second ATLB entry involving an excessive RAT probe temperature indication was made in the flight immediately following the above on the same day, 19 August.

The flight was from Madrid to Barcelona and the recorded departure time was 18:22. Specifically, in the 38L sequence in the ATLB the pilots wrote the following: *"During taxi, RAT goes to 90 °C, EPR's below 1.30 (same as seq 36)"*. That was the last segment flown that day by the airplane, which remained in Barcelona until the next day.

Once in Barcelona, the technician inspecting the airplane (TM2) first noted that there was no electrical current flowing through the probe resistance, meaning that the fault described by the crew in the ATLB was not present at that moment. Two other technicians who later went on shift confirmed this finding.

After consulting the AMM, the TM2 performed the check specified in the AMM, Chapter 34-18-00, Section 2, on the description and operation of the RAT and TRP. The check was satisfactory, and the fault described in the ATLB could not be reproduced, as had happened to the TM1 in Madrid.

As a result of the maintenance actions performed, the TM2 made the following entry in the ATLB at 03:00 on 20 August: *"RAT/TRI test performed acc AMM 34-18-00 resulting satisfactory"*.

The third and last ATLB entry made involving an excessive RAT probe temperature was on 20 August 2008 (sequence 46L), while taxiing prior to the accident in Madrid. On that day the airplane had already flown from Barcelona to Madrid, departing at 08:55, without any RAT probe anomalies being detected.

Specifically, the entry corresponding to the 46L sequence, made at 13:00, said *"Before take off RAT temp rises to 99 °C and EPR lim down to 1.38 with TO selected RAT probe heater active on GND"*.

This RAT probe high temperature reading resulted in the airplane returning to parking stand R11 at Madrid-Barajas airport to be inspected by maintenance personnel.

The technician (TM3) verified the fault described in the ATLB, checked the corresponding RAT probe heating section (30.8⁹) in the Minimum Equipment List (MEL) and proceeded to open the breaker (Z-29) for the electrical circuit that powered the heater. Following this it was proposed and accepted that the airplane be dispatched since icing conditions were not forecast on the route from Madrid to Las Palmas.

As a result of the maintenance action performed, the TM3 made the following entry in the ATLB at 13:55: *"C/B Z-29 pulled and placarded tx to HIL system must be checked A/C released acc MEL"*.

Data extracted from the DFDR also indicate that a high RAT probe temperature was recorded with the airplane on the ground (see Section 1.4.2 of this report) a total of 6 times, from 18 to 20 August 2008 (including the three described in ATLB sequences 36L, 38L and 46L).

1.3. Flight recorders

In keeping with operational regulations in effect at the time of the accident¹⁰, the airplane was equipped with a digital flight data recorder (DFDR) and a cockpit voice recorder (CVR). A quick access recorder (QAR) was also installed on the airplane.

Digital flight data recorder (DFDR)

Manufacturer: Honeywell

Model: SSFDR

P/N: 980-4700-042

S/N: 9228

The DFDR records 64 parameters and covers a 100-hour period.

⁹ Section 30.8 of the MEL, "Ram Air Temperature Probe Heater", includes the following note: "Remarks or exemptions: May be inoperative provided that: (PL) [Placard]. Flight is not made in known or forecast icing conditions".

¹⁰ Regulation (EC) no. 1899/2006 of the European Parliament and of the Council, of 12 December 2006. Joint technical requirements and administrative procedures applicable to commercial transport by airplane. OPS 1: Commercial Air Transport, in effect since 16 July 2008 (known as EU OPS regulations). Subpart K. Paragraphs OPS1.710 and OPS 1.725.

Cockpit voice recorder (CVR)

Manufacturer: Sundstrand (Honeywell)
Model: AV-557-C
P/N: 980-6005-079
S/N: 9228

The CVR features four (4) channels of audio data, which recorded the 32 minutes prior to the time of the accident.

Quick access recorder (QAR)

Manufacturer: Teledyne Control
P/N: 2248000-41
S/N: 284

1.3.1. *Recovery of recorded information*

The DFDR and CVR were recovered from the aircraft wreckage the same evening of the accident. They showed signs of impact damage and of having been affected by fire. The recorded information contained in them was successfully recovered at the AAIB¹¹ laboratory in the United Kingdom.

The airplane was equipped with two digital flight guidance computers (DFGC), such that one is always functioning during airplane operations and the other is in standby. It has been verified that the no. 2 DFGC was in operation during the taxi and takeoff phases prior to the accident. The flight parameters sent to the DFDR from the no. 2 DFGC were not properly recorded, probably due to a problem with the connection between the DFGC and the flight data acquisition unit (FDAU). These parameters are as follows:

Horizontal stabilizer position, elevator position, angle of attack, left outboard spoiler position, right inboard spoiler position, left aileron position, rudder position, slats position (left and right sides), autopilot engaged, WOW left and right main landing gear.

The remaining parameters were properly recorded.

¹¹ The AAIB (Air Accident Investigation Branch) is the official investigative body for transportation accidents in the United Kingdom.

The QAR was recovered from the aircraft wreckage some days later. The optical magnetic disk where the QAR records information had been installed on the aircraft in early August 2008. The equipment manufacturer, Teledyne, downloaded the information contained on the disk at its facilities only to discover that the data were from another of the operator's airplanes and from previous flights. There was an incompatibility between the recording formats used by the equipment and those used to record to the disk.

1.3.2. *Information contained on the flight recorders*

The CVR and DFDR were synchronized by means of the communications between the aircraft and the control tower at the airport at the time the clearance was issued for the accident aircraft to takeoff. The synchronization errors were verified to be less than two seconds.

For the sake of clarity and consistency with the reference time used in this report, the description that follows uses local time. The sequence of events below starts from the time the aircraft was first cleared to taxi after its stopover in Madrid.

The graphs showing the trends of certain DFDR parameters are included in Appendix 1.

At 13:13:57¹², the DFDR began recording data. At the start of the recording a RAT probe temperature of 56 °C was registered. It increased until it reached a value of 104 °C. The flaps indicated being extended 11°.

The crew left stand T21 and taxied via taxiway M to the head of runway 36L. Once there, they were cleared for takeoff at 13:25:03¹³.

At 13:26:27 the crew informed ATC that they had a problem and had to exit the runway.

At 13:29:00 the DFDR recording was interrupted. The heading at that point was 185°¹⁴. At 13:33:12 the crew informed ATC that they had to return to the stand, and at 13:33:47 the DFDR recording resumed. The aircraft then received instructions from ATC to return to parking.

The DFDR recording was interrupted once more at 13:42:50. The reading for the flap deflection remained at 11° throughout the entire DFDR recording interval from the start

¹² One of the design conditions specified for the installation of a DFDR on this airplane is that the recording start when the parking brake is released and that it stop when it is set.

¹³ The information from the conversations between the aircraft and ATC during those times for which CVR data are not available was obtained from the recordings of the communications made at the ATC facilities.

¹⁴ The course is measure positively clockwise starting from N.

of the taxi until this time. The RAT temperature probe recorded while taxiing back to the stand was 104 °C.

The CVR recording started at 13:51:22, at which time the DFDR was not recording. The conversation held in the cockpit involved the use of dry ice to try to lower the temperature of the probe. At that time the cockpit was occupied by the crew, maintenance technicians and another person who was entering and leaving (purser and another Spanair captain).

At 13:51:48 the captain noted that they were significantly behind schedule and that they had to record what had happened.

At 13:53:21 the captain asked the purser if it was hot in the passenger cabin, to which the purser replied affirmatively.

At 13:53:54 the captain said they could go since icing was not forecast. The maintenance technician (TM3) agreed and told them the airplane was being dispatched with the temperature probe heating inoperative.

At 13:54:34 the copilot made a comment that they could not perform a flex takeoff¹⁵.

At 13:57:47 the copilot held a private telephone conversation on his mobile in which he noted they were still in Madrid and were delayed, and told the other party of the need to change their plans.

At 14:02:36 the captain reported that he was disembarking to take on fuel and requested crew to inform the passengers.

At 14:07:02 the copilot requested ATC clearance for engine start-up on the taxi frequency instead of the clearance frequency. After tuning in to the proper frequency, ATC clearance was received at 14:08:08.

At 14:08:43 the crew started the first checklist prior to engine start-up (Prestart) "below the line"¹⁶.

At 14:08:50 the second checklist before engine start-up checklist was done (Before start). The captain anticipated certain items on the list before they were read by the copilot¹⁷.

At 14:09:01, the engines were started. During this process the crew discussed whether or not to perform a manual takeoff.

¹⁵ A flexible takeoff (FLEX) is one of the modes which can be engaged in the Thrust Rating System.

¹⁶ See Section 1.5, Operational procedures, for an explanation of this expression.

¹⁷ According to the company's operational procedures, the checklists on the ground are read by the copilot and read back by the captain. The items which the captain anticipated were seat belts, doors, anti-collision and cabin report.

At 14:12:08 the After Start list was initiated. Before reading the last item, flaps/slats, the captain told the copilot to request taxi. Before the list was read there was no record on the CVR of the captain mentioning the word flaps. While waiting for their taxi clearance they calculated the EPR, which is heard to be 1.95. They again discussed doing a manual takeoff or using auto thrust.

ATC made them wait a few minutes and at 14:14:23 the captain asked ATC how much more of a delay they could expect.

They were cleared to taxi at 14:14:33, at which time the DFDR recording resumed. From the start of the taxi phase the DFDR parameter for flap deflection indicated 0°. This value remained constant throughout the recording.

The taxi checks were completed and then, at 14:15:56, they read the Taxi checklist. When they reached the last point (Takeoff briefing) the copilot read it, but no reply was heard from the captain on the CVR.

At 14:16:39 they were requested by ATC to change frequency.

At 14:16:50 they changed frequency and started talking in the cockpit about the malfunction they had had and how it had been solved. At that time they were taxiing on M-15, M-16, M-17 and R-5. There was a third person in the cockpit taking part in this conversation. At 14:18:14, the copilot mentioned once more that the auto throttle was not going to work.

At 14:18:58, when they were on R-5, ATC informed them to switch to the takeoff frequency. The crew contacted takeoff control and reported their position on R-5. They waited on R-5 and talked about another aircraft that was taking off. The third person also took part in this conversation.

At 14:21:05 they were cleared to taxi into position and hold.

At 14:22:06 two pings were heard in the cockpit. This is the signal given by the purser to tell the pilots that the passenger cabin is ready for takeoff. The copilot started the Takeoff Imminent list. At that time the aircraft was taxiing on Z-2 and making a right turn. The copilot read all the items on the list, which the pilot read back. The recording reveals that the copilot did the final items on the list, saying "Final items, we have... sorry, eight, eleven, stowed, eleven, stowed...". He immediately started talking about the possibility of engaging the autopilot as soon as they took off.

At 14:23:09 the aircraft was cleared for takeoff, which the pilot acknowledged.

At 14:23:10 the throttles were pushed forward and then, at 14:23:19, the brakes were released.

Interim Report A-032/2008

At 14:23:29 an EPR value of 1.4 was reached.

At 14:23:31 the crew noted that the auto thrust system was not working and they had to perform a manual takeoff. Nine seconds later an EPR of 1.95 was reached.

During the takeoff run the "sixty", "one hundred", "V1", "power check" and "rotate" call outs were heard. At the time of the V1 call out the speed recorded on the DFDR was 154 kt, and the speed recorded at "rotate"¹⁸ was 157 kt.

At 14:24:10 the DFDR recorded the change from ground mode to flight mode, as indicated by the ground sensing system in the nose gear.

During the entire take-off run and until the end of the CVR recording there is no sound recorded related to the TOWS concerning an inappropriate take-off configuration.

At 14:24:14 the stall warning stick shaker was activated. The copilot said "engine failure" in a questioning tone and a second later, at 14:24:15, the captain, in a very loud voice, asked how to turn off the voice. Their speed at that time was 168 kt, they were at a radio altitude of 25 ft, a pitch angle of 15.5° and a right bank of 4.4°.

The bank to the right increased to a maximum of 20°. At that time there was about a 4-degree variation in the left throttle position and 32 degrees in the right in the retard direction that lasted for a second. As a consequence of this, the EPR a couple of seconds later dropped to 1.65 on both engines, with variations in the engine parameters also being noted. The throttles were then immediately advanced to the maximum position possible, resulting in an EPR of around 2.15. These values remained constant until the end.

From that time on the "bank angle" warnings were heard coming from the enhanced ground proximity warning system (EGPWS). The horn and synthetic voice indicative of a stall condition ([horn] stall, [horn] stall, [horn] stall) were heard three (3) times in the cockpit, sometimes overlapping the EGPWS warning. The stall warning stick shaker remained engaged until the initial contact with the ground.

At 14:24:19 the maximum values of pitch (18.3°) and radio altitude (40 feet) were reached.

The initial impact with the ground was heard at 14:24:24, with a vertical acceleration of 3.17 g. At that time the aircraft's recorded attitude was 10.4° pitch and 5.3° right bank. The speed was 154 kt.

¹⁸ Voice in English that calls out the takeoff rotation speed.

1.4. Inspections, tests and research

1.4.1. Flaps/slats

1.4.1.1. Inspection of the wreckage at the accident site

Five (5) flap actuators, three (3) from the right wing and two (2) from the left wing, were identified at the accident site. Four (4) of those actuators could be extended and retracted freely since they no longer had hydraulic pressure, while the fifth evidenced considerable damage from the fire to which it had been subjected after detaching from the wing structure, and could not be moved.

The two (2) slat control actuators were found and identified, as were the rails that act directly on the three (3) sections

A total of six slat rails were recovered, found in the following conditions:

Left half-wing:

Support rail for no. 0 slat section	Limited range of motion
Sliding rail for no. 0 slat section	Blocked in fully retracted position
Support rail for no. 1 slat section	Limited range of motion
Sliding rail for no. 1 slat section	Blocked in fully retracted position

Right half-wing:

Sliding rail for no. 1 slat section	Blocked in fully retracted position
Support rail for no. 1 slat section	Blocked in indeterminate position

All of these components had been exposed to the fire and showed signs consistent with a slats retracted condition.

The slat control valve was also found, in its location above the right half-wing root. It had been severely affected by the fire and had seized.

1.4.1.2. Inspection of flap/slat lever

The lever was recovered from the remains of the central pedestal, which showed considerable impact damage, especially to its right side, which was partially destroyed. The wheel used to adjust the notch on the right track of the flap lever was missing, as was its indicating window.

The flap/slat lever was still in its position, attached to the same pedestal axis as the adjustable track and, like the track, could be freely moved about the axis. The left stub, which is normally lodged in the fixed sliding track, had come out of the track and was appreciably twisted. The track was in place. A conspicuous mark was noted in the slot corresponding to the UP/RET position.

Both the flap/slat lever as well as the fixed track were removed from the pedestal and sent to the Instituto Nacional de Técnica Aeroespacial [National Aerospace Technology Institute] (INTA) laboratory for analysis.

There were friction marks in the internal walls along the path of the fixed track, consistent with normal contact of the pin with these walls.

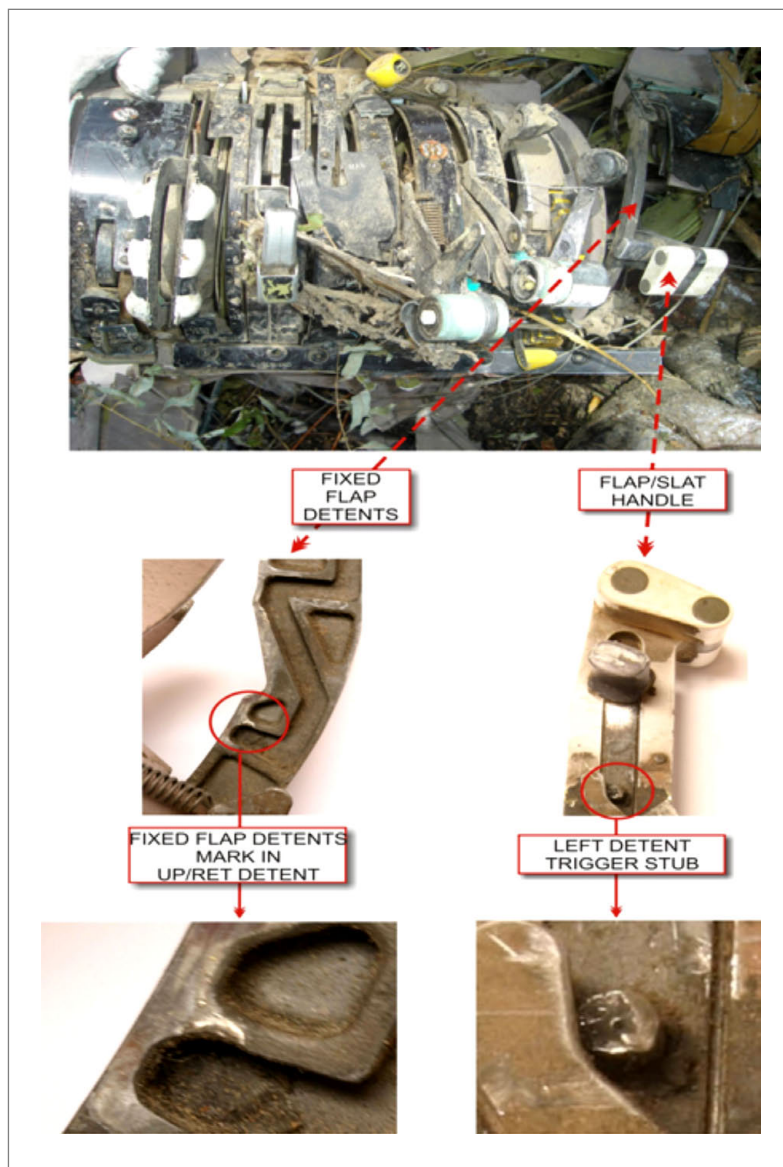

Figure 5. Detailed views of the flap/slat lever

The track showed damage at the bottom of the housing corresponding to the mark for the UP/RET position. This damage consisted basically of a deformation of the material situated in the area adjacent to the bottom of the housing, where there was an elliptically shaped imprint on the wall of the track and drag marks on the surface of the deformed material. There was also indented material at the exit of the housing along the outer surface of the track.

On the inside of the track situated in front of the damaged wall noted in the paragraph above there was an elliptically shaped mark halfway along the wall.

There was considerable damage to the external flat surface and to the cylindrical surface of the fixed-position indicator stub.

After both components were studied, it was determined that the damage evident on the track probably resulted from the hard impact between the fixed-position indicator stub on the slats/flaps lever and the track and the subsequent relative movement between the pin and the track.

These signs are consistent with the flap/slat lever being in the UP/RET position at the time of the impact between the stub and the track.

1.4.2. *Study of the conditions under which the high RAT probe temperature episodes occurred with the accident airplane on the ground*

As part of the investigation, a correlation was made of the RAT probe temperatures with other parameters, such as barometric altitude, airplane speed, ground/flight signal and time for the purpose of identifying possible patterns in the appearance of anomalies.

As mentioned in section 1.3.1, between 18 and 20 August 2008 a total of six high RAT probe temperature readings were recorded on the DFDR while the airplane was on the ground. No previous high-temperature readings were recorded on the DFDR. These six cases have been identified with the numbers 1, 4, 5, 6, 7 and 9 in Figure 6 (the time on the graph is UTC).

The airplane's ATLB only mentions three of these six high-temperature readings. Each of the three entries was made by a different crew. The first two were made on 19 August and the last on 20 August 2008.

A study of the DFDR recordings reveals the following information:

- The total sequence from the first high-temperature reading recorded on the DFDR includes nine flights. It spans three days with two prolonged intermediate stays on the nights of 18-19 and 19-20.

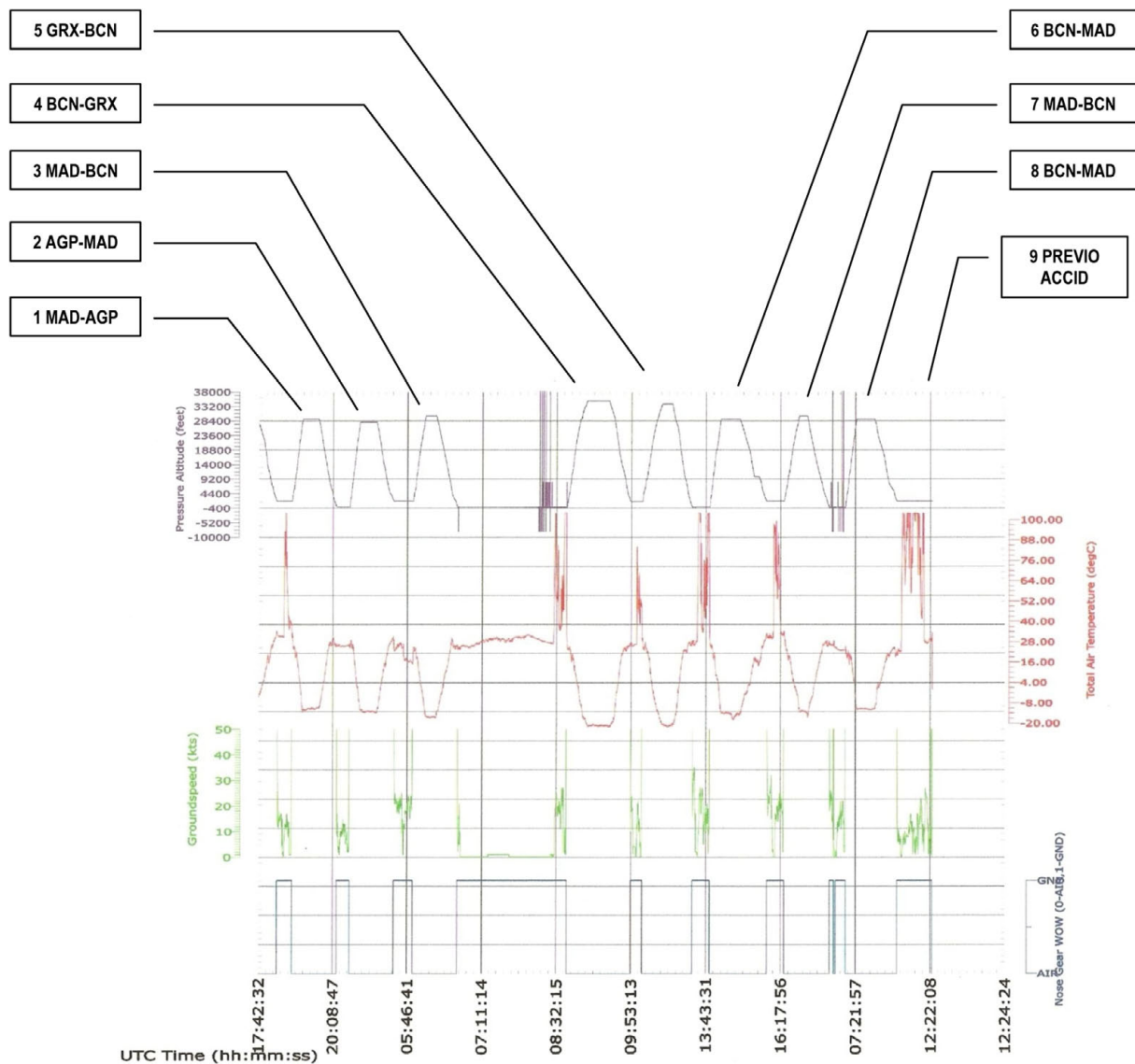

Figure 6. DFDR records of high temperature in RAT probe. EC-HFP

- The RAT probe was heated on the ground on six occasions. The average event duration was 14:50 minutes (maximum 33 minutes, minimum 5 minutes).
- The recorded high RAT probe temperature events, on a day-by-day basis, took place on the 6th flight of the first day, the 2nd, 3rd, 4th and 5th flights of the second day, and the 2nd flight of the third day, immediately prior to the accident.
- On none of the three days was the high RAT probe temperature recorded on the day's first flight.
- An inverse relationship between airplane speed and the temperature indicated by the RAT is revealed, possibly due to the probe being cooled by the ram air produced by the airplane's motion while taxiing, leading to a reduction in its temperature.
- After takeoff, the temperature readings indicated normal values, possibly due to the cooling of the probe by the ram air.

- There were no cases of probe heating after takeoff since the probe is disconnected by the crew turning the rotary switch meter selector and heat.

1.4.3. Relay R2-5 on ground sensing system

The relay installed in the R2-5 position of the aircraft's ground sensing system had been manufactured by Leach Corporation, with P/N 9274-3642. On the relay housing was the inscription "MFR 58657-9208", indicating the batch number (58567) and the date of manufacture (week 8 of 1992).

It was hermetically sealed relay with four sections with three contacts each, capable of withstanding a 28V DC or 115 V AC (400 Hz) 10A current. Its specifications indicate a life expectancy of 100,000 cycles.

It was recovered from the aircraft wreckage, joined to a part of its support plate on which there were a total of eight relays (see Figure 7). There was impact damage on the contacts located on the top side, on the cover, on one of its sides and on the base. In addition, the cover was partially lifted and there were fragments missing from its corners.

The R2-5 relay was inspected to determine if it could have failed. It was subjected to a visual inspection, a boroscopic inspection and a radiographic test. It was also subjected to continuity and functional tests. For the time being it has not been possible to disassemble the relay completely so as to study its internal components in detail.

Copious residue was noted on the outside of the cover, with a large amount of sand between all the contacts. Once the residue was cleaned, it was noted that two contacts

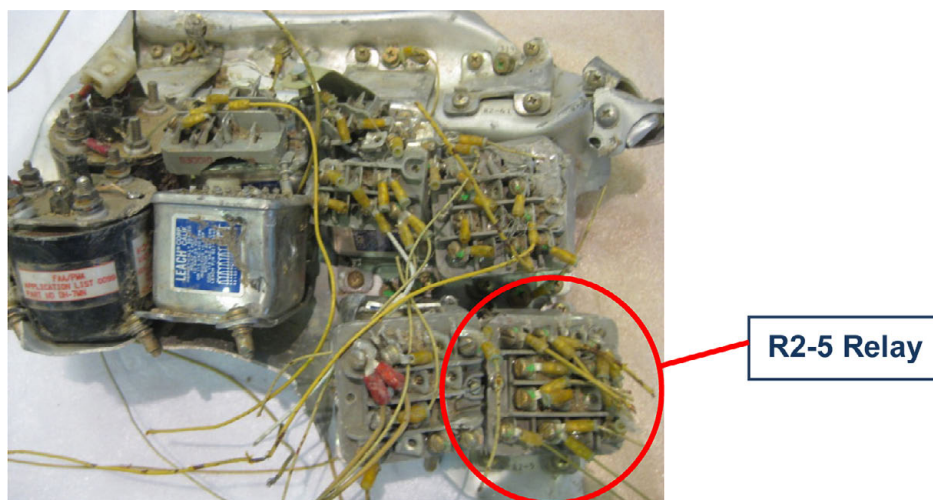

Figure 7. Recovered relay assembly which houses R2-5

had deformed to the point of touching at the part furthest from the cover. A boroscope was used to examine the inside of the cover by means of the holes left by the missing pieces. Residue deposits were also seen on the inside as far as the boroscope could reach. There were no broken connections between the contacts and their respective entry points into the sealed part of the relay.

The radiographic inspection consisted of taking radiographies and a high-resolution computerized tomography scan of the relay. The results revealed that there were no detectable anomalies in the internal components.

The functional test was conducted by referencing the relay specifications supplied by Boeing and Leach Corporation. As a preliminary measure, a small teflon sheet was placed between the contacts that had become joined so as to insulate them electrically. The relay was within specifications for the first test, at ambient temperature and with the coil stationary. The relay coil was then verified to activate as specified when a voltage was applied and that it deactivated when the supply voltage was lowered to within the specified margin. With the relay energized, however, an abnormal behavior was detected when the relay was kept energized at a nominal 115 volts, namely a general reduction of the insulation between the contacts. Moreover, contacts 1 and 2 in section C, which should be closed when a nominal voltage is applied, separated as the relay became hot. It was noted that the relay heated to a temperature of 57 °C, whereas a new relay under the same conditions did not exceed 40 °C.

The results do not allow for a determination to be made of any possible link between the defects found with the relay and the abnormal operation of the RAT probe heating and the TOWS over the course of the accident. What is more, it cannot be concluded from the tests conducted whether the defective behavior exhibited by the relay was a consequence of the damage suffered in the accident.

It is believed that the complete disassembly of the relay, which to date has not been feasible, could provide valuable information in answering the above questions.

1.4.4. *Ground test on similar airplane*

To aid the CIAIAC in its investigation of the accident, the NTSB carried out a ground test on an MD-88 airplane at Ronald Reagan National Airport in Washington D.C.

The test attempted to reproduce the possible conditions of the Spanair airplane on the day of the accident. In considering the results it is worth noting that the systems on the MD-88 are not identical to those on Spanair's MD-82, though the architecture of these systems is sufficiently similar insofar as the TOWS is concerned for the conclusions to be applicable to the MD-82.

The following cases were considered:

- K-33 breaker for the left relay assembly on the ground sensing system, open.
- Breaker Z-29 for the RAT probe heater circuit, open.
- Breakers K-33 and Z-29, open.
- Simulated failure of relay R2-5 (power supply cable disconnected).
- Simulated failure of R2-5 relay and breaker Z-29 open.

The test gave the following results:

- With the TOWS operating normally and only the breaker for the RAT probe heater (Z-29) open, the TOWS activated when the flaps and slats were not properly configured for takeoff as both throttle levers were advanced.
- With breaker K-33 open, the TOWS did not provide any warnings as both throttle levers were advanced when the flaps and slats were not properly configured for takeoff. In addition, the following indications were observed in the cockpit:
 - Failure of stall indication system,
 - Increase in indicated RAT probe temperature,
 - The rack cooling system (avionics fan) was off,
 - The N2 rpm indicator for the left engine was 15% higher than that for the right engine, and
 - The “No Autoland” indicating light turned on.
- With the R2-5 relay disconnected from its power supply, the TAT reading increased considerably since the RAT probe heater was energized. The TOWS did not issue any warnings when the throttle levers were advanced. Under these conditions, there was no indication available to the test participants of the status or condition of either the R2-5 relay or the TOWS.



Figure 8. Comparison between the recovered relay and a new one of the same model

1.5. Operational procedures

1.5.1. *Spanair Operations Manual*

1.5.1.1. General criteria applicable to the checklists

The system of checklists established by the operator defines a set of instructions for flight crews on how to perform their jobs.

The section of the Operations Manual applicable to the operator's MD80 fleet in effect at the time of the accident specifies, when referring to the general criteria for the expanded checklists¹⁹, that the lists are to be read and read back in a loud and clear voice. It explains that the use of terms "set" or "checked" as replies are an indication that the element in question has been adjusted or that the relevant piece of equipment is operating normally. It also states that the term "as required" should not be used as a reply, the position or indication read on the element in question having to be specified. As for the way to complete the lists, the instructions indicate that upon completion, the list name should be stated followed by the expression "checklist completed".

The "Prestart" checklist must be performed in its entirety before the first flight of the day and when deemed necessary by the captain. During crew turnovers or on intermediate stops, if both pilots leave the aircraft, the entire list will be performed, but without it being necessary to do the items intended to check the equipment, only those that verify switch positions. It is not necessary to do the shaded items on the list if one of the pilots remains onboard.

Every item on the list will be completed and then checked. On the ground, the PF and PNF will do the actions on the list, as defined on the expanded checklists. The pilot in the RH seat will read the list, and the pilot in the LH seat will reply.

The Operations Manual does not specifically address interruptions that take place when preparing for a flight when a malfunction occurs that requires returning to the stand. There is a reference to the situation where a list is not completed, in which case the list is to be placed in a conspicuous location so as to remind the pilots that the task is still pending.

1.5.1.2. Before takeoff checklists on the MD-80 series

The company's normal procedures envisage the following checklists for the MD-80 series before initiating the flight:

¹⁹ OM-B MD-80. Section 2. Normal Procedures. Chapter 1. Normal Check List. Subchapter 2. Expanded Check List. Rev. 00 (02.05.2007).

Checklist	No. of items
Prestart	59 (first flight of the day) 26 (if one of the pilots remains onboard during stopovers)
Before start	8
After start	9
Taxi	8
Take off imminent	6

Each item on the lists has a series of actions associated with it. By way of example, item 29 on the Prestart list refers to the emergency lights and consists of seven actions. To the above we must add the engine start procedure.

Prestart

The check of the TOWS is item no. 49 on the list. It is a shaded item, meaning it is required only before the first flight of the day. It warns that if the horn does not sound when performing the system check, maintenance action is required prior to takeoff.

Item no. 31 involves "Ice Protection". As with the previous one, it is a shaded item, meaning it has to be done in its entirety only prior to the day's first flight. This item includes a total of seven actions to check the de-icing systems. The heat for the temperature sensors (pitot tubes, static pressure ports, angle of attack transducers and RAT probe) would only be energized if the outside temperature is below 6 °C.

In the Prestart checklist, there is a dashed line after item 56. The expression "below the line" means that the last three items on the list (57, 58 and 59) below the dashed line are to be read.

After start

Last in this list (item no. 9) is the selection of the flaps/slats. The reply to this item is "SET & CHECKED". The detailed description given in the expanded checklists includes a specific note that indicates that the flaps must be extended when the all-clear signal is received from the ground.

This item is performed by the copilot by selecting the flap extension to that obtained previously from the performance calculations. Both pilots must check that the sequence of the slat indicating lights is correct. Most of the company pilots interviewed were of

the opinion that the performance of this point is conditional upon the captain asking for it expressly when ground operators give the all clear, at which time the copilot extends the flaps and both pilots check for the proper sequence of slat lights.

Item no. 4 on this list refers to "Ice Protection & Fuel Heat". This item is done by the captain and involves energizing, among other things, the RAT probe heater. The reply to this item is "SET".

Taxi

The last item on this list (no. 8) is "Take Off Briefing". The description of this item specifies that takeoff speeds, thrust and flaps, among others, be reviewed.

Takeoff imminent

Last on this list (item no. 6) are the so-called final items. The Operations Manual does not specify how to perform this item. The company pilots interviewed agreed that this item is spoken out loud by the copilot from memory without the captain having to reply. The pilot must supervise the copilot, ensuring that the replies, spoken out loud, correspond to the actual condition of the systems and with the setpoints selected. The settings for takeoff critical components are checked, including the flap and slat indicators.

1.5.2. *Boeing FCOM*

The introduction to the section on Normal Procedures in the Boeing FCOM applicable on the date of the accident lists the following norms with respect to the checklists:

- The pre-flight checklists are performed by using a scan pattern and applying the DO-VERIFY technique (do the item and then verify completion).
- The lists should be read in a clear and loud voice and replied to in a similar manner.
- The terms "SET or CHECKED" as a reply indicate the selection or operation of the equipment, depending on existing conditions or the equipment configuration. It also states that the term "AS REQUIRED" should not be used as a reply. The element's position or indication has to be specified.
- At the end of each list, the list's name should be stated followed by the expression "checklist completed".
- The checklists included in the manual do not specify the distribution of tasks between the flight crew.

Before start

The items in this list are not numbered, although there are around 75. The following note appears at the beginning:

NOTES: All system checks and control positions should be done, whenever possible, prior to reading the checklist. Commands preceded by an asterisk () are thru-flight items.*

Item no. 65 corresponds to the TOWS check. It indicates that if when the TOWS check is performed there is no sound, then maintenance is required prior to takeoff. This item is marked with an asterisk.

Item no. 35 on the list is the one associated with the sensor heaters (Pitot Heat). It requires checking the sensor heaters for proper operation and connecting the heaters. This item is also marked with an asterisk.

Taxi

This checklist contains 12 items. The first is a check of the flaps/slats, the selection made having to be specified. The slat indicating lights have to be "on" in the proper sequence.

The last item on the list is the "Takeoff Briefing". It does not specify what this item includes.

1.6. Other information

1.6.1. *Prior accidents involving inadequate takeoff configurations*

1.6.1.1. MD-82 Northwest Airlines. Detroit (USA), 1987

On 16 August 1987, a McDonnell Douglas DC-9-82 started its takeoff run on runway 3C the Detroit airport. Following the rotation, the aircraft started to bank and one of the wings impacted a light pole, and then other light poles, before finally hitting the ground. The aircraft was destroyed as a consequence of the impact and ensuing fire. A total of 148 passengers and 8 crew members died. One passenger was seriously injured. In addition, two persons on the ground were killed and 4 seriously injured.

The NTSB determined the probable cause of the accident as a failure of the flight crew to use the taxi checklist to ensure the flaps and slats were properly configured for takeoff. The investigation revealed that the lack of power to the TOWS resulted from a

circuit breaker that may have either malfunctioned or opening it intentionally by the crew. The reason for that absence of power was not determined.

During the investigation, in September 1987, McDonnell Douglas issued a telex to all DC-9-80 operators, recommending them to modify their checklists to ensure the TOWS was checked prior to each flight.

1.6.1.2. B727 Delta Airlines. Dallas-Fort Worth (USA), 1988

On 31 August 1988, Delta Airlines flight 1141 crashed just after taking off from runway 18L at the Dallas-Fort Worth airport, Texas. The aircraft was a Boeing 727-232, with 101 passengers and 7 crew members. The crew stated that the takeoff run was normal, with no luminous or aural warnings issued.

Just after takeoff the aircraft started to bank, as a result of which it hit the antenna for the instrument landing system (ILS) localizer.

The aircraft was destroyed by the impact and the subsequent fire. Of those aboard, 12 passengers and 2 crew members died. Twenty-one passengers and five crew members were seriously injured, with 68 passengers receiving minor injuries.

The NTSB determined the probable cause as:

1. A lack of discipline in the cockpit by the captain and copilot, which resulted in attempting to take off without the flaps and slats properly configured.
2. The failure of the TOWS to alert the crew that the aircraft was improperly configured.

The investigation concluded that the switch that completes the circuit to energize the TOWS was not closed. It was also noted that there was contamination on the internal contacts of said switch. This switch was associated with the operation of the throttle for the number 3 engine.

1.6.1.3. B737 Mandala Airlines. Medan (Indonesia), 2005

On 5 September 2005 at 03:15 UTC, a B737-200 operated by Mandala Airlines, registration PK-RIM, crashed during takeoff at Medan airport, Indonesia.

Of the 117 people onboard, 5 crew members and 95 passengers died, 15 passengers were seriously injured and 2 were unhurt. On the ground 49 people died and 26 were seriously injured. The aircraft was completely destroyed by the impact and ensuing fire.

The investigation revealed that the aircraft was not adequately configured for takeoff. The flaps and slats were not extended.

The Indonesian NTSC²⁰ determined the following circumstances as the probable cause:

- The aircraft took off in an improper takeoff configuration, with the flaps and slats retracted, which resulted in the aircraft having insufficient lift.
- The inadequate execution of the checklists meant the retracted position of the flaps went unnoticed.
- The TOWS warning horn could not be heard on the cockpit area microphone on the CVR. It is possible that the TOWS alarm did not sound.

1.6.1.4. Incidents reported to the NASA ASRS²¹ system

A check was made of the database for NASA's aviation safety reporting system (ASRS). Fifty-one cases involving TOWS warnings were identified, distributed as follows:

Aircraft models	Number of cases	Takeoff attempts with inappropriate wing configuration
MD-Series	13	4
B737 Series	24	15
B757 Series	5	4
Others	9	4

Of the four takeoff attempts without flaps by MD series airplanes, two resulted from forgetting to either partially or completely perform a checklist.

In every case involving B737 series airplanes, the normal execution of the procedures was interrupted for various reasons.

In one case, also involving a B737, the airplane actually took off without flaps. At an altitude of approximately 100 feet, the stick shaker activated, which made the copilot realize the flaps were retracted, at which point he extended them. The failure of the TOWS to provide the corresponding improper configuration alarm was attributed to a tripped circuit breaker.

²⁰ The National Transportation Safety Committee (NTSC) is the official investigative body for transportation accidents in Indonesia.

²¹ NASA's ASRS is a system for gathering information on accidents, incidents, rules violations or other civil aviation events provided voluntarily by pilots. The contents of these notifications are not subject to verification.

1.6.2. *Previous incidents involving high RAT probe temperature indications on the ground*

1.6.2.1. Cases compiled by Boeing

Boeing supplied a list of the notifications received from operators involving cases of elevated RAT probe temperature readings on the ground or which involved the R2-5 relay for the period from 2000 to the end of 2008.

There were a total of 103 faults reported by operators during which an excessively high or different from outside ambient temperature was detected by the RAT. These cases were resolved as follows:

- 71 were solved by replacing the R2-5 relay.
- 18 by replacing the RAT probe
- 1 by replacing both R2-5 and the RAT probe
- 2 were deferred in accordance with the MEL
- 1 by replacing the TRI (Thrust Rating Indicator)
- 1 by resetting the LH Ground Control Relay (K-33)
- 2 by way of other maintenance procedures and in the remaining 7 cases the fault could not be reproduced.

Of the 71 cases in which the R2-5 relay was replaced, on at least 8 of those occasions it was noted that the relay was “stuck” in a set position.

Of the 18 cases where the RAT probe was replaced, in at least 13 the anomaly did not involve an excessive temperature indication, but rather a difference between indicated and outside temperatures.

From those 103 cases, at least on 6 of them it was reported that the high temperature indication decreased or re-established to normal values while the aircraft was taxiing or during take-off.

1.6.2.2. Cases reported by Spanair

Spanair had recorded two high-temperature cases in its MD fleet on airplanes different from the accident airplane. The first took place on an MD-82 on 1 September 2006 at Barcelona airport, with the airplane returning to the stand up to three times while taxiing before the fault was fixed. As the crew noted in the ATLB, the temperature recorded by the RAT probe while taxiing rose to 90 °C, at which point the crew returned to parking to request technical assistance. The first time maintenance personnel reset the TRI panel and accomplished the required functional test for the system, indicating that the fault status be reported on subsequent flights. When the airplane taxied again, the same condition was noted, and so the crew returned once more to

have maintenance to fix the problem. On this occasion, the maintenance technicians replaced the R2-5 relay, which seemed to solve the problem. During the taxi of the next scheduled flight, however, the same fault occurred. Maintenance discovered that the reason was contact between two wires from different systems (taxi lights and RAT probe heating) belonging to the same cable bundle in the nose wheel housing. The affected wires are supplied by 115V AC and the contact between them when the taxi lights were on was supplying the RAT probe heater.

The second case involved an MD-83 on 25 May 2008 in Palma de Mallorca. The crew described in the ATLB how after engine start-up, the RAT temperature increased and the red-off flag appeared on the indicator. In this case maintenance reset the K-33 circuit breaker for the LH ground-sensing system. After this it was repeatedly observed how the RAT probe readings were correct and the airplane was returned to service.

The next day, after landing in Barcelona, the pilots noted how the probe heating was engaged while the airplane was on the ground. This time maintenance rendered the RAT indicating system inoperable by opening the Z-29 breaker, which supplies power to the probe heater. This fault was logged as deferred in accordance with the MEL. Before the airplane's next flight, the Spanair Operations Control Department pulled the airplane from the schedule to avoid delays, which gave maintenance additional time to work on the fault. The R2-5 relay was then replaced, after which the probe and its indicating system functioned properly. The airplane was then returned to service.

1.6.2.3. Cases reported by other operators

Information was received concerning other possible incidents involving high RAT probe temperatures in the maintenance records for four operators that fly MD series airplanes. In all, the sample analyzed comprises a fleet of over 100 airplanes and spans a 15-year period.

The information compiled shows that in two of the operators involved, there were no recorded failures of that component. A third operator had detected four cases of high-temperature readings provided by the RAT probe between August 2006 and August 2008. After different maintenance activities performed in an attempt to solve these problems, in three of the cases the fault was solved by the eventual replacement of the R2-5 relay. In particular, in one of these cases it was noted that the R2-5 relay was stuck. In the remaining case, in which the R2-5 relay was not replaced, the anomaly was fixed by replacing the RAT temperature probe.

The maintenance records for the fourth operator revealed a total of 22 cases of high RAT probe temperature readings from October 1994 to November 2008. Every one of these faults was fixed by replacing the R2-5 relays. In those records where the model for this component was specified, it matched that installed on the accident airplane.

1.6.3. *Prior faults during pre-flight check of the TOWS*

Boeing reported that it is aware of 13 cases in which it was notified by operators during the period from 2000 to 2008 in which a failure of the TOWS was noted during the pre-flight checks, and which were solved by replacing the R2-5 relay, and of another six (6) cases of combined high RAT probe temperature indications and TOWS fault during the check, of which four (4) were also solved by the replacement of the R2-5 relay. To date no data are available on the total number of TOWS faults detected during this check and reported to Boeing.

1.6.4. *Measures taken*

1.6.4.1. *Airworthiness directive issued by the EASA*

On 29 October 2008, the European Aviation Safety Agency (EASA) issued airworthiness directive EASA AD No. 2008-0197 (see Appendix 2), with an effective date of 12 November 2008 and applicable to McDonnell Douglas airplane models DC-9-10, DC-9-20, DC-9-30, DC-9-40 y DC-9-50, DC-9-81 (MD-81), DC-9-82 (MD-82), DC-9-83 (MD-83) and DC-9-87 (MD-87); MD-88; MD-90-30 and 717-200

This directive required that the AFM section on procedures be revised within 15 days from the effective date to add the requirement to check the TOWS before engine start-up and prior to each flight.

1.6.4.2. *Safety alert issued by the FAA*

On 5 November 2008, the FAA issued SAFO 08021, "Importance of Standard Operating Procedures (SOP) as Evidenced by a Take.off Configuration Hazard in Boeing DC-9 Series, MD-80 series, MD-90, and B-717 Airplanes" (see Appendix 2).

This SAFO made reference to the 1987 McDonnell Douglas telex which recommended that operators check the TOWS before each flight and indicated that the risk of improperly configuring the flaps and slats could be mitigated in two different ways: warning systems and standard operating procedures.

The SAFO recommended that Operations, Maintenance, Safety and Training Managers review their procedures to ensure that the maintenance and operating procedures are effective in ensuring the proper operation of the TOWS. It also urged proper training for maintenance personnel to ensure the approved procedures for the airplane type in question were followed.

The instructions contained in the SAFO are not mandatory.

1.6.4.3. Modifications to operational procedures made by Spanair

Since the accident, Spanair has revised its Operations Manual²² twice, in September 2008 and in March 2009. Specifically, the following changes were made to Part B, Chapter 2, Normal Procedures:

- The preface was modified to specify that the complete Prestart list be performed, including the systems check, after any maintenance activity.
- The TOWS item in the Prestart list was modified to have the check performed on every flight.
- An item was added at the end of every checklist to expressly indicate the completion of said list.
- The Taxi checklist was modified to include a check of the flaps in item number 7.
- Item 6 on the Take Off Imminent list, concerning the final items, was modified to specify that both pilots must perform them, with each item being read by the pilot in the RH seat and checked and read back by the pilot in the LH seat.

1.6.4.4. Modifications made to Operations Manual by Boeing

In October 2008, Boeing modified its FCOM as result of a previous no flaps/slats take-off event, to include the check of the flaps/slats as a new item, number 3, on the Before Take Off list.

In March 2009, Boeing published a new version of its FCOM that included a definition of the terms "First Flight of the Day" and "Through Flight". According to these definitions, the first flight of the day is the first made by a crew on an aircraft, even if they have flown together previously that same day.

Through flights are defined as flights that make up a series of consecutive flights made by the same crew on the same aircraft and to which the following conditions apply:

- There are no changes to the crew during the stopover.
- At least one flight crew member remains onboard the airplane during the stopover.
- All the busses remained energized while on the ground.
- All the items required to be checked on the first flight of the day have been completed.
- Only normal maintenance activities are performed.
- The inertial reference units (IRU) are reset.

²² Spanair OM-B MD-80, revision 2 dated 12/09/2008 and revision 3 dated 1/03/2009.

2. DISCUSSION

On 20 August 2008 at 14:24, a McDonnell Douglas DC-9-82 (MD-82) aircraft, registration EC-HFP, operated by Spanair, suffered an accident immediately after takeoff from Madrid-Barajas airport, Madrid, Spain. The aircraft was destroyed as a consequence of the impact with the ground and the fire.

The data from the investigation indicate that the takeoff maneuver took place with the flaps and slats retracted, which constituted an improper configuration that did not ensure safety. The inspections of the slat components recovered from the accident site showed evidence consistent with a slat retracted condition. In addition, though an inspection of the flap components did not yield a definitive conclusion regarding their position at the time of the accident, the values recorded on the digital flight data recorder (DFDR) indicate that the flaps remained retracted for the length of the taxi phase to the runway, the takeoff run and throughout the entire accident sequence until the recorder ceased operating following the impact. Furthermore, the laboratory tests conducted on the flap actuating lever recovered from the wreckage revealed the existence of impact marks located in the position corresponding to the flaps/slats retracted (UP/RET), possibly caused by the lever itself.

The operator had standard operating procedures and checklists in place for pilots to prepare the airplane for its safe operation, to include setting and confirming the proper wing configuration for takeoff. The accident pilots referred to these procedures but because of factors such as the interruption posed by the return of the aircraft to the stand due to a malfunction, the pressure caused by the delay in the schedule or deficiencies in the working methods used in the cockpit, the procedures were not strictly followed and it is not obtained the safety protection that standard procedures are intended to provide.

The CVR recordings revealed that the item to set and check the flap/slat lever and lights on the After Start checklist was omitted. On the CVR it can be heard how the copilot performs the final items on the Takeoff Imminent checklist and reviews the values for the position of the center of gravity (eight) and flaps (eleven) on the takeoff adjustment panel situated on the pedestal, and how he repeats the flap angle (eleven), which he should have been reading off the LCD flaps/slats indicator window and off the graduated wheel on the flap/slat lever. The physical evidence and the data recorded for the flaps on the FDR, however, contradict what the pilot is heard saying on the CVR. Given the way the flaps/slats system operates, it is highly unlikely that both LCD indicators, which receive their information directly from the sensors located on the flaps, would have shown 11° if the flaps had been retracted. This would have required for the sensors on both wings, which are independent, to transmit faulty information, and which, moreover, would have had to be 11° for both. The check of the final items, therefore, is not considered to have represented an actual check of the cockpit indicators. The most likely conclusion, then, is that the flaps and slats were not extended for takeoff by the crew.

On the other hand, data from the investigation also indicate that the system responsible for warning the crew of an improper takeoff configuration (TOWS) did not activate. The sound of the synthetic voice and the horn warning that the flaps and slats retracted was not heard on the cockpit voice recorder (CVR). In accordance with the system's design specifications, the horn should have sounded when the crew advanced the throttle levers for takeoff.

Based on these conclusions, the CIAIAC is of the opinion that three safety barriers provided to avoid the take-off in an inappropriate configuration were defeated: the airplane configuration checklist, the checklist to confirm and verify the airplane's actual configuration, and the TOWS, which did not warn of the improper takeoff configuration. As a consequence, improvements should be taken in the area of design and operations so that future accidents as this one can be prevented.

2.1. Check of TOWS prior to takeoff

The system on the MD-80 series that warns of an inappropriate takeoff configuration, TOWS, is programmed to alert the pilots when the flaps, slats, trim, parking brake, auto brake and/or spoilers are not properly configured for takeoff.

The system is designed to be active only on the ground and to be inhibited in flight.

In keeping with the company's Operations Manual in effect at the time of the accident, the crew should check the operation of the TOWS during the performance of the Prestart checklist before the first flight of the day²³. On subsequent flights, only the switch positions have to be checked, but not the operation of the systems²⁴. It is very likely, therefore, that the crew did not verify the operation of the TOWS during the stopover in Madrid. After the accident, in October 2008, the operator revised its Operations Manual to specify that the operation of the TOWS be checked as part of the Prestart list before each flight.

The manufacturer's Operations Manual (FCOM) specified that the check of the TOWS should be done prior to the first flight of the day and on through flights, although the meaning of that expression was not defined in the manual. The manufacturer has since amended the FCOM, in March 2009, to include the definition of that term, clarifying that it refers to intermediate flights in a series of flights made by the same crew on the same airplane.

As a result of the accident of a Northwest Airlines MD-82 at the Detroit airport²⁵, McDonnell Douglas issued a telex in September 1987 to all the operators of that

²³ In this case the first flight of the day was defined as the first flight made after 00:00 UTC.

²⁴ Both the Spanair Operations Manual and Boeing's FCOM include other systems that are not checked prior to each flight, such as the GPWS or the ACAS.

²⁵ The NTSB conducted the investigation of the accident, whose results are presented in report No. NTSB/AAR-88/05.

airplane type, recommending that the TOWS be checked prior to each flight. At the time the accident report was issued, it was stated that every operator in the United States had incorporated that change to its operating procedures.

Based on the initial data on the investigation provided by the CIAIAC, the European Aviation Safety Agency issued Airworthiness Directive AD 2008-0197 on 29 October 2008. This directive amends the airplane flight manual for DC-9, MD-90 and B717 series airplanes by including a mandatory check of the TOWS before engine start-up on each flight. It is applicable to every operator of these aircraft in the European Union.

After the EASA issued Airworthiness Directive 2008-0197, the FAA in the United States, on 5 November 2008, issued a safety alert for operators (SAFO 08021²⁶). The SAFO makes reference to the McDonnell Douglas telex recommending that operators perform the TOWS test prior to each flight. The SAFO emphasizes that the risks of improperly configuring the slats and flaps can be mitigated by adhering to TOWS operating procedures (SOP) and maintenance procedures. The message recommends that Operations, Maintenance, Flight Safety and Training Managers revise their procedures to make them effective in ensuring a proper TOWS operation, and that they train their maintenance and operations personnel properly. The SAFO refers to the procedures recommended by the manufacturer as the primary reference.

As mentioned previously, the data from the investigation suggest that the TOWS did not generate an improper configuration warning. In this case, a check of the system prior to the flight could have detected a potential fault, or would have at least increased the chances of detecting it. Spanair's procedures did not stipulate that the system be always checked prior to each flight. The instructions contained in the manufacturer's FCOM at the time of the accident were not fully clear on the matter since the meaning of the expression "through flight" had not been defined. The telex used by McDonnell Douglas over twenty years ago to inform of the procedural changes after the MD-82 accident in Detroit, and which recommended the TOWS be checked before each flight, may not have had the desired effect on companies, such as Spanair, that only later started operating this aircraft. Moreover, both the manufacturer's FCOM and the recommendations in the telex are guidelines for the operators to aid them in drafting their own procedures. The operators are free to deviate from the manufacturer's recommendations with the involvement²⁷ of the civil aviation authorities under whose regulations the operators engaged in their activities.

²⁶ "Importance of Standard Operating Procedures (SOP) as Evidenced by a Take-off Configuration Hazard in Boeing DC-9 series, MD-80 series, MD-90, and B-717 Airplanes".

²⁷ The involvement of civil aviation authorities in the procedures and checklists of airline operators has different effects, depending on the legal terms (approval, acceptance, oversight, etc.) customary for describing the responsibilities of said authorities. For example, the EU OPS regulations define the terms accepted and approved as follows:

"accepted" or "acceptable" means not objected to by the Authority as suitable for the purpose intended
"approved (by the Authority)" means documented (by the Authority) as suitable for the purpose intended.

Both the operator and the manufacturer revised their procedures following the Barajas accident. Spanair now requires that the TOWS check be performed before every flight, in accordance with the recommendations of the manufacturer, which has provided a detailed definition of the term “through flight”. Additionally, the European Aviation Safety Agency now requires all operators in the European Union to conduct the check, in keeping with the changes made to the procedures section in the MD-80 series aircraft flight manuals.

The CIAIAC shares in the philosophy expressed in the SAFO issued by the FAA, stressing the need to adhere to the operational and maintenance procedures made available by the manufacturer for that system, including the recommendation that it be checked before each flight. By not being obligatory, however, the measures proposed in the SAFO may not have the desired effectiveness from an operational safety standpoint. In this sense, the action taken by the EASA, which modified the flight manual for airplanes of this type, is thought to be a more appropriate response, though it is restricted exclusively to operations in the European Union. The issuance of mandatory instructions, in the way of airworthiness directives, by the Authority responsible for the type design for these airplanes, would undoubtedly have a more wide-reaching effect on the global MD-80 fleet, due to the adoption of this Airworthiness Directive that would in practice take place in many of the States of registration, increasing the likelihood that both operators in the United States and around the world outside the European Union performed the TOWS check prior to each flight.

Therefore:

REC 07/09. It is recommended that the FAA of the United States establish mandatory airworthiness instructions to modify the procedures contained in the aircraft flight manuals for the Boeing DC-9, MD-80, MD-90 and B-717 series so as to include a functional check of the TOWS prior to each flight.

2.2. The R2-5 relay of the ground sensing system and the TOWS

The airplane’s stopover at Barajas was delayed by an abnormal RAT probe temperature indication in the cockpit. The crew noticed the high TAT value and returned the aircraft to the stand from the head of the runway to have it checked by company maintenance personnel. The DFDR logs confirm that the probe reached a temperature of 104 °C.

When the aircraft arrived at the stand, maintenance personnel verified the fault as described in the ATLB, checked the appropriate section in the Minimum Equipment List for the RAT probe heater, 30.8, and proceeded to open the circuit breaker²⁸ that

²⁸ The circuit breaker for the RAT probe heater is identified as Z-29 in the central electrical panel situated in the cockpit behind the LH seat.

supplies the heater. It was then proposed and accepted that the airplane be dispatched. The information recorded on the DFDR during the taxi and subsequent takeoff run prior to the accident noted a maximum probe temperature of 30 °C.

The high TAT value noted by the crew during the first taxi indicated that the probe heater was energized on the ground. The heating system, however, is designed to warm the probe only while the airplane is in flight.

The way the airplane detects whether it is on the ground or in the air is by way of switches located in the nose gear. When the nose gear strut is compressed and the gear is down and locked, the condition that exists with the airplane on the ground, the switches close to complete the circuits that energize a group of relays. This is interpreted as ground mode. When the nose gear strut is fully extended, this condition existing when the nose wheel is not in contact with the ground, the switches open the circuits, which de-energize the relays. This is interpreted as flight mode. Each of these relays provides a ground-flight signal to the different systems that require this information in order to function correctly. According to the manufacturer's Wiring Diagram Manual (WDM), the R2-5 relay supplies power to the RAT probe heater as well as control signals to the avionics radio rack cooling indication, the AC cross tie and the TOWS.

In normal operations, the R2-5 relay provides an input into the TOWS when the airplane is on the ground and interrupted when airborne. The R2-5 relay also energizes the RAT probe heater when the airplane is airborne and disconnects it when on the ground.

The high temperature indication while the airplane was on the ground, then, along with the failure of TOWS to sound the horn to alert the crew during the takeoff run, could stem from a possible failure of the R2-5 relay.

The R2-5 relay was recovered from the accident site and inspected with the aim of determining if it could have failed. The relay was subjected to visual and boroscopic inspections and radiographic testing, including a high-resolution computerized tomography scan. Continuity and functional tests were also carried out. To date it has not been possible to fully disassemble the relay so as to conduct a detailed study of its internal components.

The radiographic test did not reveal any defects. The conductivity tests yielded values consistent with the relay's specifications. A ground fault was measured at one of its contacts, but it was also within admissible design limits.

The functional test conducted, however, did reveal an abnormal behavior and overheating in the relay when kept energized at a nominal 115V.

The data supplied by these tests are still being analyzed. A complete disassembly of the relay could provide additional data, considered vital to determining its condition. For the

time being, therefore, there is insufficient conclusive information to determine whether a failure of the relay prevented the TOWS from working during the takeoff run prior to the accident.

The maintenance records of various operators of MD-80 series airplanes were also consulted. The information obtained involved a fleet of over 100 airplanes in all and spanned 15 years. A total of 26 records were found of RAT probe heating on the ground. In 25 of those cases, the malfunctions were solved by replacing the R2-5 relay. It was not possible to determine how long the replaced relays were installed.

Data compiled by the manufacturer, Boeing, since 2000 include 103 cases of improper heating of the RAT probe on the ground, though in 13 did not involve a high temperature *per se*, but rather deviations with respect to ambient temperature, meaning there were actually 90 cases worthy of consideration for analysis. In 72 of them, the problem was traced to the R2-5. The information provided by Boeing also revealed the TOWS failures that emerged when the system was tested prior to flight and which resulted from faults in the R2-5 relay.

In the days prior to the accident, three events were recorded in the accident airplane's ATLB detailing anomalous RAT probe heating events while on the ground. When the operator's maintenance personnel tried to solve the problem, they could not duplicate the fault. The airplane's DFDR data also indicate that three additional cases of RAT probe heating on the ground occurred between 18 August and the day of the accident that were not logged in the ATLB. Six of these cases were studied in an attempt to obtain behavior patterns and correlations with other parameters recorded on the DFDR.

All of this information can yield some important conclusions:

- The majority (80%) of the cases of known probe heating were associated with a malfunction of R2-5.
- There are cases involving a fault of the TOWS during the pre-flight check directly related to failures of the R2-5. No information is available for estimating what percentage of faults detected during pre-flight checks of the TOWS are due to malfunctions in R2-5.
- There are cases when anomalous RAT probe heating episodes occur on the ground. They do so intermittently, such that periods of normal probe heater operation are interspersed with periods of faulty operation.
- The probe temperature decreases as the taxi speed on the ground increases, which hampers detection by the flight crew.
- Faulty probe heating events could have taken place and gone unnoticed by the flight crew and maintenance personnel.
- Anomalies involving high probe temperatures cannot always be reproduced during maintenance.

- None of the six high probe temperature instances recorded on the DFDR of the accident airplane took place before the day's first flight, when the TOWS check would also have been done.

In short, it is uncertain whether the R2-5 relay failed on the accident airplane, or that such possible failure could have resulted in a fault of the TOWS. The inspections and tests that were able to be performed on this relay to date have proved inconclusive. However, data reviewed by the investigation suggest that a further review of the R2-5 relay's reliability and the effect its failure may have on the TOWS may be appropriate. In addition, the circumstances of the accident indicate the need for further evaluation of the flightcrews' ability to receive timely indication of an inoperative TOWS in those cases involving difficult to detect failure modes.

The ground test conducted as part of the investigation by the NTSB on an MD-88 airplane at Washington airport showed how a limited fault of R2-5, which was simulated by disconnecting the relay from its power source, resulted in a fault of the TOWS. With the flaps and slats improperly configured for takeoff, the TOWS horn did not sound when the throttles were advanced. It was also noted that the simulated fault in R2-5 was not evident to the participants in the test, and that the inoperable condition of the TOWS went unnoticed. The only abnormal indication received was an elevated RAT probe temperature. This single reading does not convey clearly and unequivocally to the crew the possible presence of a fault in R2-5 and that the TOWS is disabled. Known data from the Spanair accident are consistent with the conditions present during the test. If these conditions existed, the Spanair crew could hardly have correlated the high RAT probe temperature, the fault of relay R2-5 and the inoperability of the TOWS. Maintenance personnel called out to solve the problem were also unaware of this interconnection²⁹.

There is, therefore, evidence that in a high percentage of cases, the R2-5 relay is the source of the faults affecting the RAT probe heater. The 100 hours recorded on the accident airplane's DFDR have been of invaluable help in revealing the symptoms that could be indicative of RAT probe heating on the ground. It has also been noted that the R2-5 relay was the direct cause of TOWS malfunctions. It is believed that these factors could be related, which would mean that R2-5 has failure modes that affect the RAT probe and the TOWS and which could be of an intermittent nature and difficult to detect.

What is more, there is no way to track those R2-5 relays installed in a given airplane since these parts are replaceable and not identified individually. It is typical of pieces such as relays, including R2-5, to have maintenance actions performed "on condition".

²⁹ The discussion regarding the maintenance instructions available for trouble shooting the malfunction involving the heating on the ground of the RAT temperature probe on these airplanes was the object of a safety recommendation issued by the CIAIAC in February 2009 (REC 01/09).

They are not subject to specific inspections, and therefore the data available to determine their reliability or service life are limited. Neither the manufacturer of the R2-5 relay nor of the aircraft has those data. In this case the R2-5 relay had been manufactured in 1992. As stated above, there can be no certainty that it was installed on the airplane when its assembly was completed in November 1993. Supposing that the relay had always been installed on the airplane, it would have shared the airplane's 28,133 cycles. For each airplane cycle (number of takeoffs), it can be assumed that the relay went through two cycles³⁰, meaning it would have accumulated a total of 56,266 cycles, less than its design life of 100,000 cycles. Even if the R2-5 relay did fail in this case, a single example would not serve to determine the reliability of the relays. That would require an exhaustive check of service records, if available, to reach more solid conclusions.

In light of relay R2-5's importance to the operation of the TOWS, this system being critical to safety, an evaluation should be done of the relay operating conditions, its actual in-service life expectancy, its reliability and its failure modes. Maintenance instructions should also be defined specific to this component based on the results of the evaluation. Therefore:

REC 08/09. It is recommended that the European Aviation Safety Agency and the FAA of the United States require Boeing to evaluate the operating conditions, in-service life, reliability and failure modes of relays in position R2-5 of the ground sensing system in DC-9, MD-80, MD-90 and B-717 series airplanes, and that it specify a maintenance program for this component based on the results of said evaluation.

2.3. Considerations on the criticality and reliability of takeoff warning systems in the MD-80 generation of airplanes

At the time of the MD-80 series certification, there were no requirements for TOWS³¹. This requirement was imposed in March 1978 with the inclusion of paragraph 25.703 in the FAR 25 certification regulation. Even so, many airplanes, including the MD-80, that had been certified previously, had a TOWS.

FAR paragraph 25.703 requires that the TOWS provide the crew with an aural warning during the initial phase of the takeoff run when the airplane is configured such that a safe takeoff cannot be guaranteed. The criterion used by the FAA to certify these systems was to consider them as a back-up for crews, meaning they were classified as

³⁰ An airplane cycle consists of a ground-air-ground sequence. Assuming that the airplane is powered down on each stopover, the relay coil will be energized twice during each airplane cycle, one on landing and again when power is supplied for the next flight.

³¹ The certification regulation for the MD-82 was FAR 25, up to amendment 25-40, which went into effect on 2 May 1977.

non-essential systems when it came to defining their criticality. This category is reserved for those systems whose faults are not considered to result in an unsafe condition in the aircraft, nor reduce its performance nor the crew's ability to handle adverse operating conditions.

In the European Union, the European Aviation Safety Agency adopted specification CS-25 as the certification code for large airplanes in October 2003. This regulation comes from the JAR-25 standard, developed within the framework of the JAA³². The requirement to install a TOWS is in paragraph CS25.703, in effect since January 1979³³. In general, the requirements and criteria of the FAA and European Aviation Safety Agency with regard to the TOWS are the same.

The study³⁴ undertaken by the FAA after the Northwest Airlines MD-82 accident in Detroit shows that over the period from 1958 to 1987, there were 12 accidents or major incidents worldwide that involved an inadequate takeoff configuration. In every case the TOWS outfitted in those airplanes was designed to the non-essential level of criticality requirements stipulated by the certification regulations and a reliability analysis was not required when they were certified.

Counting only the accidents referred to in this report (see Section 1.6.1), including the accident involving EC-HFP, in which there were errors in the takeoff configuration, there were 475 fatalities. According to NTSB figures, there have been 49 accidents of this nature worldwide since 1968.

In the Northwest Airlines MD-82 accident in Detroit, the NTSB concluded that there was an absence³⁴ of electrical power to the TOWS that impeded it from warning the crew of the inadequate takeoff configuration. The investigation was able to narrow down the electrical fault to a circuit breaker in the CAWS power supply circuitry. Whether this absence of electrical power was due to a breaker malfunction or to an intentional action that opened the breaker could not be determined.

In the accident of a Delta Airlines B727 in Dallas, the TOWS failure occurred because the electrical switch for the circuit that activates the TOWS horn did not close. That switch is associated with the advance of the throttle for the number 3 engine. The accident report revealed that the TOWS installed on the B727 suffered from intermittent failures that were not easily detectable and that the system had significant reliability concerns. As a result it was recommended that the FAA study the system in depth, placing special emphasis on the installation of the switch on the throttle lever and that

³² The Joint Aviation Authorities (JAA) comprises the civil aviation authorities of most European, and some non-European, States. Its mission is to standardize civil aviation regulations in Europe and to harmonize them with those of other States. Its responsibilities in this domain ceased on 30 June 2009, at which time they were under the purview of the European Aviation Safety Agency.

³³ JAR-25, Amendment 5.

³⁴ Aircraft Certification Division. FAA. April 29, 1988, pp., 22-23. Review of take off configuration warning systems on large jet transports.

an airworthiness directive be issued making mandatory whatever changes were derived from the study³⁵.

In the accident report for the Mandala Airlines B737-200, the Indonesian NTSC thought it was possible that the TOWS had not sounded during takeoff with the flaps and slats retracted. The investigation did not go any further in confirming that possibility.

Data from the Spanair MD-82 accident indicate that it is possible for a fault in relay R2-5 to render the TOWS inoperative.

The Detroit, Dallas and Barajas accidents show that the TOWS can be disabled on the ground by a simple fault in one of its components. The reports for the Detroit and Dallas accidents called into question the reliability of certain TOWS components in airplanes like the B727 and the MD-82. The investigation into the Spanair accident has shown that a fault in one of the TOWS components, the R2-5 relay, can lead to a failure of the system. Its classification as a non-essential system is behind these problems. The TOWS on airplanes of the MD-80 series, B-727 and B737-200 lack redundancy because the function of the TOWS is viewed as one of back-up for the crew in its preparations for the flight. Experience, however, has shown that the human factor, in conjunction with first-generation takeoff warning systems, is not enough of a barrier to prevent accidents resulting from configuration errors.

In contrast, the MD-80 series Master Minimum Equipment List does not allow the airplane to be dispatched with the TOWS inoperable.

A fault of the TOWS requires that the airplane be grounded until the system is repaired prior to flight, as per the Minimum Equipment List. The same fault can go unnoticed by the crew since the system does not provide any type of warning to alert it that the TOWS has failed.

Another possibility is that a failure of the TOWS could occur after the TOWS is checked by the crew but before takeoff, thereby leaving the airplane in a non airworthy condition without the crew being aware of the situation.

It is inconsistent, therefore, to maintain the "NO GO"³⁶ nature of the TOWS in the MEL without modifying its condition as a non-essential system and which exempts it from having additional safety devices such as, among others, a crew warning in case of a system failure or a redundant design that makes it less vulnerable to a simple fault, as was the loss of electrical power to the TOWS in the case of the Detroit accident in 1987, or as might be the case of a failed R2-5 relay that supplied the ground-flight signal in the Barajas accident.

³⁵ Safety recommendations issued by NTSB A-88-125 and A-88-126.

³⁶ A "NO GO" element refers to those systems or components whose fault prevents the dispatch of the airplane as per the MEL.

In reply to a safety recommendation³⁷ issued by the NTSB in its report on the Detroit accident, the FAA published circular AC 25.703.1 in 1993. The EASA counterpart is AMC 25.703, which establishes the criteria currently accepted by the European Authority for certifying the TOWS designs in transport airplanes. According to these criteria, previously designed TOWS could not be regarded as having a suitable level of safety when the consequences of a fault in the system coupled with an inadequate takeoff configuration could lead to major or catastrophic fault conditions³⁸. Therefore, in keeping with these guidelines, the safety level of these systems should be increased to classify them as essential, in accordance with FAA AC 25.1309-1A and its EASA counterpart, AMC 25.1309, such that both the FAA's and the EASA's current interpretation is that of considering the inoperability of the TOWS as having severe effects on safety.

The 1988 FAA study mentioned (see note 34) recommended that the reliability of the TOWS, such as those outfitted on the MD-80 generation of airplanes, be improved by forcing these systems to comply with the same requirements as for essential equipment. However, the in-service experience available at the time along with the accident history did not seem to justify the adoption of such a measure.

Given the current situation, and keeping in mind the history and the consequences of accidents due to faults in the takeoff configuration which coincided with single failures in the warning systems, it does not seem sufficient to address only those problems which have been discovered with the design of these systems, such as the switch on the B727 throttle lever or the reliability of the breakers in the power supply circuit as was the case with the MD-82 in Detroit, or a possible fault in the R2-5 relay now. These systems have to be revised in depth so that they can provide crews with an effective defense while minimizing latent fault conditions that could affect their components.

Therefore:

REC 09/09. It is recommended to the European Aviation Safety Agency and to the FAA of the United States that the design of Takeoff Warning Systems be reviewed in transport airplanes whose certification standards did not require the installation of such systems or which, if they did require it, did not apply to them the guidelines and interpretation provided by AMC 25.703 in the case of the EASA, or circular AC 25.703 in the case of the FAA. The goal of this review should be to require that the TOWS comply with the applicable requirements for critical systems classified as essential in CS 25.1309 and FAR 25.1309.

³⁷ Recommendation A-88-66 issued by the NTSB asked the FAA to develop and issue guidelines for the design of the CAWS to include a determination of the warning to be provided, the criticality of the provided warning and the degree of self-monitoring these systems should have.

³⁸ AC 25.1309 defines system criticality based on the severity of the effects that a failure would have on safety. The failure conditions are classified according to the severity of their effects as minor, major and catastrophic.

2.4. Certification of critical systems

Apart from accidents, the database of the NASA notification system (ASRS) yielded 52 cases in which pilots reported TOWS warnings on various airplanes which fortunately did not end in an accident. These data indicate that even highly experienced pilots with flawless records can err when establishing and verifying the configuration for takeoff, especially if the procedures were interrupted by some unusual circumstance. The rate of these errors, which are normally the result of oversights, could hardly have been anticipated at the time airplanes of the MD-80 generation were certified. It seems necessary, then, that certifying authorities take into consideration the history of these events along with all the design options available when certifying current and future airplanes.

The history of accidents has shown that pilots alone cannot provide an adequate barrier against mistakes. Takeoff warning systems have become extremely useful tools for alerting the crew and in practice represent one of the last safety barriers available to them to keep from taking off without a correct configuration. These systems must be considered as essential in light of the obvious human limitations against errors. The criteria currently applied by certification authorities consider these factors when evaluating the suitability of the TOWS, but they are not applied systematically since they were not properly incorporated into the regulations. We have seen how the TOWS in airplanes of the MD-80 generation can be rendered inoperative by a simple fault for which the crew has no warning. Current certification standards would also allow these conditions to be present in the design of modern airplanes. As a result, this Commission believes that certifying authorities should review the requirements demanded of these systems so as to increase their reliability and the protection they provide. Therefore:

REC 10/09. It is recommended that the European Aviation Safety Agency and the FAA of the United States revise regulations CS-25 and FAR 25, respectively, on the certification of large transport airplanes to add a requirement that ensures that Takeoff Warning Systems (TOWS) are not disabled by a single failure or that they provide the crew with a clear and unequivocal warning when the system fails.

An NTSB study on critical systems in transport airplanes³⁹ published in 2006 made two safety recommendations⁴⁰ that highlighted the need to consider the human error variable in evaluating the operational safety requirements for the certification of critical systems subject to structural failures. It also asked that the aviation industry import those methods already adopted by other transportation sectors, such as the automotive, for

³⁹ National Transportation Safety Board, Safety Report on the Treatment of Safety-Critical Systems in Transport Airplanes, Safety Report NTSB/SR-06/02 (Washington, DC: NTSB, 2006).

⁴⁰ NTSB recommendations A-06-37 and A-06-38.

the ongoing assessment of these evaluations throughout the life cycle of the airplanes in keeping with operational experience.

These recommendations are also considered pertinent to the remaining critical systems, such as TOWS, whose designs should make allowances for the lessons learned from accidents and serious incidents and for how these systems interact with human actions. The TOWS, therefore, should be understood as being within the intended scope of these recommendations that the NTSB issued to the FAA, and thus EASA would also keep in mind the history of pilot errors when configuring airplanes for takeoff when assessing the behavior of these systems to determine whether the assumptions made during the certification of the design are still valid. Therefore:

REC 11/09. It is recommended that the European Aviation Safety Agency revise the accompanying guidelines and the clarifying material for the CS-25 certification regulations for large transport airplanes so as to consider the human errors associated with faults in takeoff configurations when analytically justifying the safety of the TOWS, and to analyze whether the assumptions used when evaluating these systems during their certification are consistent with existing operational experience and with the lessons learned from accidents and incidents.

2.5. Operational procedures and checklists

Checklists constitute a supremely important element for the safety of aviation transport operations. The lists are used in all phases of flight. Prior to takeoff, for example, the lists are intended to prepare the airplane for safe operation.

Properly designed checklists and procedures and adherence thereto are particularly relevant when configuring the airplane for takeoff, since any errors could have fatal consequences in this phase of flight. Therefore, an insistence on improved procedures associated with the use of checklists can reduce the likelihood of a mistake when preparing and configuring the airplane for takeoff.

While the complexity of these lists should be limited, they are in fact implemented in a wide variety of ways among airplanes from different manufacturers or between airplanes of different types from the same manufacturer. Despite the knowledge, supported by various studies⁴¹, that errors associated with the use of checklists have contributed to a significant number of accidents, and that those errors occur with relative frequency over the course of operations, the design of checklists is a

⁴¹ These include, among others: Lautmann, L. & Gallimore, P. (1987). Control of the crew-caused accident: Results of a 12-operator survey. Boeing Airliner. Boeing Commercial Airplane Company (Seattle), Helmreich, R.L., Wilhelm, J.A., Klinect, J.R. & Merritt, A.C. (2001). Culture, error, and crew resource management.

field that was virtually ignored until after the Northwest Airlines accident in Detroit in 1987.

Based on the conclusions drawn from the Northwest Airlines accident in Detroit, the NTSB issued a safety recommendation⁴² that has served to develop the field of research into human factors as it relates to the making of checklists. Some of the norms that emerged from this research⁴³ were, for example:

- During the execution of the lists, have the answers reflect the values of the parameters selected instead of simply replying with expressions like “checked” or “set”.
- The most critical items should be at the beginning so as to improve the chances of completing those items in case of interruptions. It is even recommended that those points be revisited at the end of the list, so as to doubly ensure their execution.
- Critical points such as flaps/slats or trim, which may be readjusted due to new information, for example a last minute change of runway or variations in wind speed, should be duplicated on those check lists applicable while on the ground and be confirmed by both pilots.
- The last point on a checklist should be an oral confirmation of its completion so as to provide the crews with the certainty that the list is in fact finished and they can go on to another task.

These criteria are generally featured on the checklists prepared by manufacturer and operators, although it cannot be said that they are universally adopted by both. For example, the Spanair lists in effect at the time of the accident did not include the principle of having the flight crew announce out loud the values selected for the flaps. Moreover, the selection of flaps and slats was the ninth and last item on the After Start list. Although the values selected were checked in the last items section of the Takeoff Imminent list, these were only reviewed by the copilot and from memory, without a reply from the captain. As for Boeing’s FCOM, it reflected the principle of calling out the numeric value of the flap extension when selecting them, although other items in different lists were acknowledged with a “set” or “check”. Also in keeping with the FCOM, the flap/slat lever was the first item checked on the Taxi checklist, though they were not verified at any subsequent point.

⁴² In safety recommendation A-88-68, the NTSB asked the FAA to form a research group on human factors that included representatives from NASA (National Aeronautics and Space Administration), the industry and pilots so as to determine methods for presenting checklists which produces better performance on the part of user personnel.

⁴³ Some of the reports and authors are:

Degani, A. & Weiner, E. L. (1993). Cockpit Checklists: Concepts, Design, and Use. *Human Factors* 35 (2), pp. 28-43. Research on checklist effectiveness followed, in part, from an NTSB recommendation resulting from the Detroit Flight 255 accident.

Turner, J. W., Huntley, M. S. Jr. Report N°. DOT/FAA/AM-91/7. April 1991. The Use and design of flight Crew checklists and manuals. A special report for the U.S. Federal Aviation Administration.

Human Performance considerations in the use and design of aircraft checklist. January 1995. U.S Department of Transportation. Federal Aviation Administration. Assistant Administrator for System Safety Office of Safety Services Safety Analysis Division.

After the accident, Spanair and Boeing revised their operating procedures for the MD-80 series of aircraft. The changes made are in keeping with the philosophy presented above. Spanair has included an item at the end of each list to expressly indicate its completion. It has also modified the Taxi checklist to add the flaps verification as item 7. Boeing added a new item, number 3, to its Before Takeoff checklist to check the flaps and slats.

More recently, investigations based on observing operator practices⁴⁴ and on pilot notifications of events, or in the analyses of some accidents, the focus has been on omissions that occur while executing procedures, such as those that may result in an erroneous configuration. The phase before takeoff, when the flaps are selected, is filled with interruptions, distractions, bursts of communications and unexpected tasks, all of which can have a negative impact on the execution of checklists even if they are designed using the best of criteria. Oversights normally occur when the execution sequence as practiced during training is interrupted by other tasks that demand the crew's attention. In the Spanair case, such interruptions were unquestionably present. There was a technical problem while preparing for the flight that required the intervention of maintenance personnel. This resulted in a new timeline and forced the pilots to delay the departure and return to the stand.

Strategies have been proposed and tested in actual operational environments in an effort to mitigate the effect of interruptions and excess work load during flight preparation operations. These proposals include crew training on managing these circumstances.

A high work load and the appearance of interruptions are factors that merit special consideration in the case of airplanes of the MD-80 generation. A significant point is that in both the Spanair procedures and in Boeing's FCOM for the MD-80 series, the checklist to be performed prior to engine start (Prestart for Spanair and Before Start in the Boeing FCOM) consists of 59 items (Spanair) and 75 items (Boeing) for the first flight of the day. The TOWS check, for example, is item 49 (Spanair) and 65 (Boeing). Each of these items, in turn, involves the execution of several actions. In a normal operational setting, it is normal for disruptions to appear which prevent the completion of such extensive lists without interruptions.

Current generation airplanes are equipped with computer-controlled instruments⁴⁵ that are effective in helping crews avoid configuration errors. One of their features is an on-screen display of checklists whose items are shown continuously to the crew until the computer confirms that the checklist actions have in fact been executed.

⁴⁴ Loukopoulos, L.D., Dismukes, R.K. & Barshi, I. (2009). *The Multi-Tasking Myth: Handling Complexity in Real-World Operations*. Aldershot, UK. Ashgate Publishing Limited.

⁴⁵ Examples of these systems are the EICAS (Engine Indicating and Crew Alerting System) from Boeing and ECAM (Electronic Centralized Aircraft Monitoring) from Airbus. Both are computer-controlled integrated systems that supply the crew with information on the engines and the instruments, and that also serve as warning systems.

These systems are also capable of making configuration checks prior to takeoff by having the computer simulate advancing the throttles and activating the relevant warnings if necessary.

In conjunction with the NTSB, the CIAIAC believes that an in-depth investigation of operational procedures should be conducted so as to avoid configuration errors during takeoff. This Commission also emphasizes the need for continued efforts to progress in this area. Improvements in the design of checklists and in the work methods used in the cockpit, such as defining the sequence of crew actions or applying the do/verify and challenge/response principles when managing the checklists, are the goal of the following recommendation. As a result:

REC 12/09. It is recommended that the International Civil Aviation Organization (ICAO), the FAA of the United States and European Aviation Safety Agency jointly promote the holding of an international conference, to be attended by every civil aviation representative organization, such as authorities, industry, academic and research institutions, professional associations and the like, for the purpose of drafting directives on good industry practices in the area of aviation operations as they apply to checklist design, personnel training and improved procedures and cockpit work methods so as to ensure that crews properly configure aircraft for takeoffs and landings.

Continuing with the checklists, there are very few examples of civil aviation authorities taking the conclusions drawn from studies and work done to date and providing them to those in charge of drafting and applying said lists, such as aviation manufacturers and operators, or to those responsible for their oversight and approval, such as civil aviation inspectors. In the United States, the FAA has drafted guidelines⁴⁶ for its operations inspectors (POI) which include the principles mentioned above on the design of checklists. These guidelines also comprise a practical reference for operators and manufacturers, who find in them the same criteria that will be used by the inspector in his evaluation, and which are also made available to the public at large. In Europe, there is the example of the CAA in the United Kingdom, which published directives⁴⁷ in 2006 on the design and use of emergency and abnormal checklists.

Along with the strategic recommendation to undertake a joint and thorough study in this area, it would be useful if an urgent effort were made to compile and disseminate the research and work already done in this area so as to make it as widely available as possible. Therefore:

⁴⁶ FAA Order 8900.1 Flight Standards Information Management System (FSIMS). Volume 3. General Technical Administration. Chapter 32. Manual, Procedures, and checklist for Part 91K, 121, 125, and 135, derived from studies conducted as a result of the 1987 Northwest Airlines accident in Detroit (1987).

⁴⁷ CAP 676. Guidance on the Design, Presentation and Use of Emergency and Abnormal Checklists. CAA, UK (January 2006).

REC 13/09. It is recommended that the European Aviation Safety Agency compile the results of studies and works done, as well as of any instructions and directives issued by civil aviation authorities to date, concerning the principles and guidelines relative to the

- design of checklists and
- working methods in the cockpit

so as to allow European operators and manufacturers and national authorities to have clear references on the state of the art in the design and application of checklists.

3. STATUS OF THE INVESTIGATION

The investigation is ongoing.

More inspections of components in the ground sensing system and of the aircraft engines are pending. The information extracted from the non-volatile memory cards in some of the airplane's systems is being analyzed. Also being studied is the airplane's performance with assistance from the manufacturer.

The human factors aspects of the airline's operations and maintenance activities will be thoroughly investigated and analyzed.

To this purpose more must be learned about the procedure used by the operator to draft and revise its checklists and the involvement of the aviation authority in this process. Also of interest to this investigation are aspects such as how interruptions during flight preparations are handled and the detachment and focus of crews on those tasks associated with the sterile cockpit concept. Crew actions before and during the flight are being analyzed, as is their discipline in complying with procedures. The training programs for flight crews are being reviewed, as well as those programs involving stall recognition and recovery on takeoff.

As for maintenance, the investigation is focusing on learning about the organization, on the allotment of resources, personnel training and technical knowledge, the decision-making processes, the criteria used for troubleshooting and line maintenance and how the documentation is handled and how repeat faults are dealt with.

Another outstanding issue concerns the operational safety programs and the authority's supervision of the operator's activities in this area.

The survival aspects and the post-accident response and management actions are also being evaluated.

At the conclusion of the investigation a final report will be issued detailing every aspect involving operational safety as it relates to this accident.

APPENDICES

APPENDIX 1

Graphs of DFDR parameters

SECOND TAXI

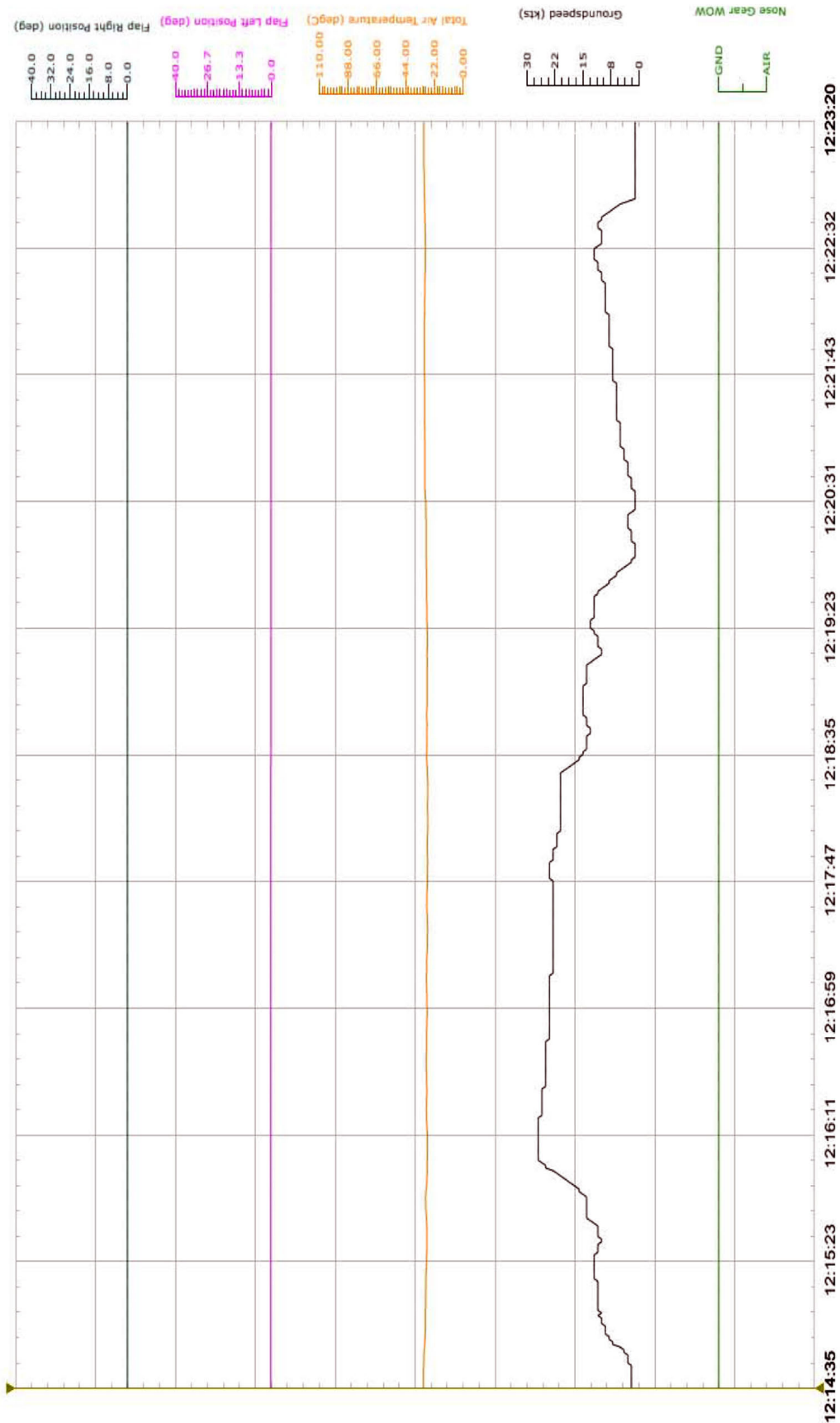

UTC Time (hh:mm:ss)

TAKE OFF ROLL: ENGINE PARAMETERS

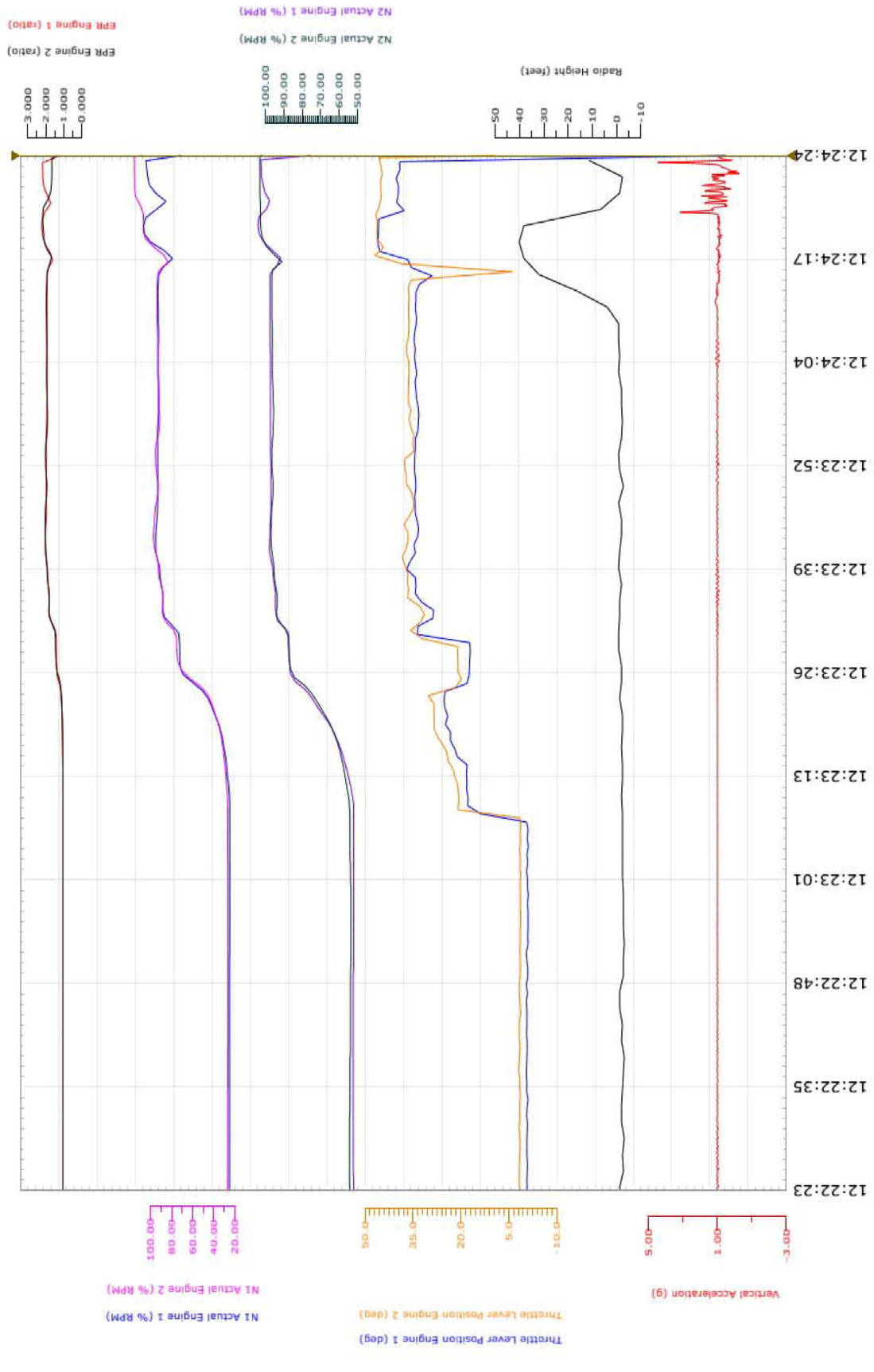

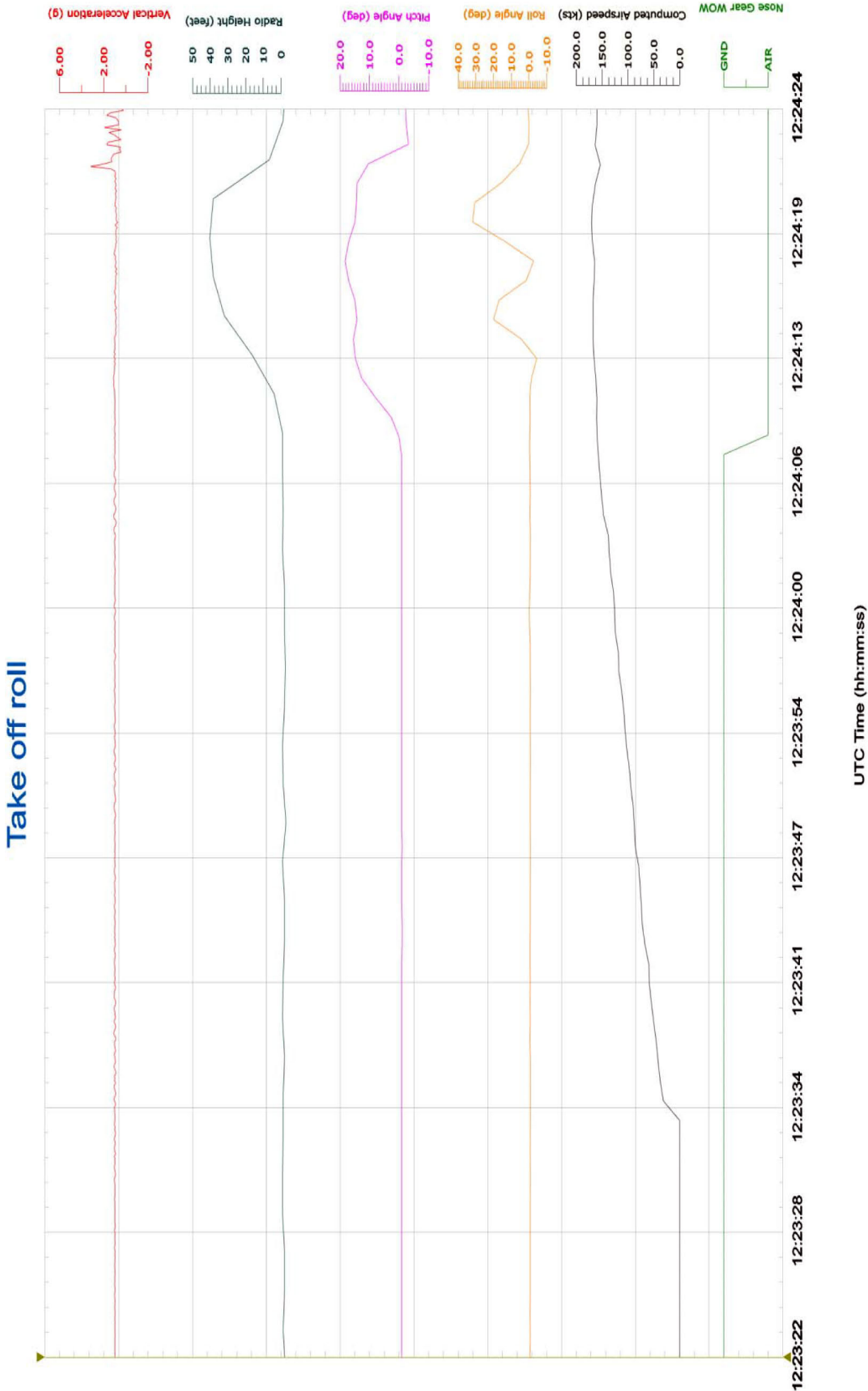

APPENDIX 2
EASA Airworthiness Directive
AD no. 2008-0197
SAFO no. 08021 FAA

EASA	AIRWORTHINESS DIRECTIVE	
	<p>AD No.: 2008- 0197</p> <p>Date: 29 October 2008</p> <p>Note: This Airworthiness Directive (AD) is issued by EASA, acting in accordance with Regulation (EC) No 216/2008 on behalf of the European Community, its Member States and of the European third countries that participate in the activities of EASA under Article 66 of that Regulation.</p>	
<p>This AD is issued in accordance with EC 1702/2003, Part 21A.3B. In accordance with EC 2042/2003 Annex I, Part M.A.301, the continuing airworthiness of an aircraft shall be ensured by accomplishing any applicable ADs. Consequently, no person may operate an aircraft to which an Airworthiness Directive applies, except in accordance with the requirements of that Airworthiness Directive unless otherwise specified by the Agency [EC 2042/2003 Annex I, Part M.A.303] or agreed with the Authority of the State of Registry [EC 216/2008, Article 14(4) exemption].</p>		
<p>Type Approval Holder's Name :</p> <p>McDonnell Douglas Corporation</p>	<p>Type/Model designation(s) :</p> <p>DC-9-10, -20, -30, -40, and -50 Series, DC-9-81/82/83/87, MD-88, MD-90, and 717 airplanes</p>	
<p>TCDS Number: U.S.A No. A6WE</p>		
<p>Foreign AD : Not applicable</p>		
<p>Supersedure : None</p>		
ATA 31	Central Aural Warning System – Airplane Flight Manual and Pre-Start Check of the Take-off Warning System – Introduction	
<p>Manufacturer(s):</p>	<p>McDonnell Douglas Corporation (previously Douglas Aircraft Co.), The Boeing Company.</p>	
<p>Applicability:</p>	<p>All McDonnell Douglas Model DC-9-10, DC-9-20, DC-9-30, DC-9-40, and DC-9-50 airplanes; Model DC-9-81 (MD-81), DC-9-82 (MD-82), DC-9-83 (MD-83), and DC-9-87 (MD-87) airplanes; Model MD-88 airplanes; Model MD-90-30 airplanes and Model 717-200 airplanes.</p>	
<p>Reason:</p>	<p>In August 2008, a McDonnell Douglas DC-9-82 (MD-82) airplane crashed while attempting to take off from runway 36L at Madrid's Barajas International Airport.</p> <p>Although the preliminary report issued by Spain's Comisión de Investigación de Accidentes e Incidentes de Aviación Civil (CIAIAC) did not identify the probable causes of the accident, it states that the data recordings suggest the flaps/slats were not set for takeoff and the Take-Off Warning (TOW) did not occur.</p> <p>After a similar accident in 1987 where it was concluded that the flaps/slats were not set for takeoff and the TOW did not occur, McDonnell Douglas recommended all MD-80 series operators conduct a check of the TOW system before engine start prior to every flight. It has been found that some operators' procedures no longer reflect the initial intent of the recommendation made by McDonnell Douglas as the check is performed less frequently.</p>	

	<p>A defective TOW system could let an improper take-off configuration undetected to the flight crew and result in loss of control during the initial climb. As a consequence, to ensure that all operators of MD-80 series airplanes perform the TOW system check before every flight, this Airworthiness Directive requires an update of the Airplane Flight Manual (AFM) to make the frequency mandatory.</p> <p>The AD also extends to the DC-9 and 717-200 aircraft as the design of the TOW system is common to all three types.</p>
<p>Effective Date:</p>	<p>12 November 2008</p>
<p>Required Action(s) and Compliance Time(s):</p>	<p>Required as indicated, unless accomplished previously:</p> <p>Within 15 days after the effective date of this AD, Amend the PROCEDURES section of the applicable Airplane Flight Manual to incorporate the following check.</p> <p>This may be done by inserting a copy of this AD into the AFM after the TABLE OF CONTENTS pages of the PROCEDURES section.</p> <div style="border: 1px solid black; padding: 5px;"> <p>TAKEOFF WARNING SYSTEM</p> <p><i>Note: This check is mandatory and must be carried out before the first engine start before every flight.</i></p> <p>Before engine start, and with power on the aircraft:</p> <p>Takeoff Warning/Throttles.....CHECK/IDLE</p> <p>Move both throttles toward full forward position and observe takeoff warning sounds. Move throttles to idle and observe warning is silenced.</p> <p><i>NOTE: If takeoff warning does not sound, maintenance action is required prior to takeoff. Confirmation of takeoff warning system operation does not ensure that correct takeoff values for stabilizer trim, centre of gravity, or flap/slats position have been set.</i></p> </div>
<p>Ref. Publications:</p>	<p>Not applicable</p>
<p>Remarks :</p>	<ol style="list-style-type: none"> 1. If requested and appropriately substantiated, EASA can approve Alternative Methods of Compliance for this AD. 2. The required actions and the risk allowance have granted the issuance of a Final AD with Request for Comments, postponing the public consultation process after publication. 3. Enquiries regarding this AD should be referred to the Airworthiness Directives, Safety Management & Research Section, Certification Directorate, EASA. E-mail ADs@easa.europa.eu 4. For any questions concerning the technical content of the requirements in this AD, please contact: <ul style="list-style-type: none"> Boeing Commercial Airplanes Attention: Data and Service Management, Dept. C1-L5A (D800-0024) Long Beach Division, 3855 Lakewood Boulevard Long Beach, California 90846, United States of America



U.S. Department
of Transportation
**Federal Aviation
Administration**

SAFO

Safety Alert for Operators

SAFO 08021
DATE: 11/5/08

Flight Standards Service
Washington, DC

http://www.faa.gov/other_visit/aviation_industry/airline_operators/airline_safety/safo

A SAFO contains important safety information and may include recommended action. SAFO content should be especially valuable to air carriers in meeting their statutory duty to provide service with the highest possible degree of safety in the public interest. Besides the specific action recommended in a SAFO, an alternative action may be as effective in addressing the safety issue named in the SAFO.

Subject: Importance of Standard Operating Procedures (SOP) as Evidenced by a Take-off Configuration Hazard in Boeing DC-9 series, MD-80 series, MD-90, and B-717 Airplanes.

Purpose: To emphasize the overall importance of SOP and specifically the need for SOP to ensure proper operation of the Take-off Warning System (TOWS) for DC-9 series, MD-80 series, MD-90 and B-717 airplanes.

Background: A recent loss of an MD-82 aircraft during takeoff and a subsequent Airworthiness Directive (AD) by the European Aviation Safety Agency (EASA) serve to underline the criticality of correct take-off configuration. The investigation of this accident is still ongoing and the probable causes have not yet been identified, however, preliminary information released by the investigating authority indicates the airplane's flaps and slats were not configured for take-off.

A review of accidents and incidents involving civil transport category aircraft shows that, worldwide, take-off configuration errors have figured in 49 accidents and incidents since 1968. These events have resulted in 392 fatalities. It should be noted that the FAA has already taken actions in response to these accidents and incidents such as revising airworthiness standards and issuing ADs. The hazard of mis-configuration of the flaps and slats at take-off can be mitigated in two distinct ways:

- 1) warning systems, and
- 2) standard operating procedures.

The recent MD-82 loss underlines the need for the industry to consider its SOP, as well as warning systems when mitigating take-off configuration hazards.

Discussion: DC-9 series, MD-80 series, MD-90 and B-717 airplanes are specifically equipped with a TOWS intended to prevent mis-configuration during take-off. Likewise Original Equipment Manufacturer (OEM) -recommended and air carrier-approved SOP have been designed to prevent a mis-configuration take-off. A warning system and SOP can only be effective mitigations if the system is properly maintained and the SOP is properly designed and followed.

The AD issued by EASA addresses SOP for DC-9 series, MD-80 series, MD-90 and B-717 airplanes. This AD revises Airplane Flight Manual SOP to require the crew to check the TOWS before engine start prior to every flight. This was previously recommended by McDonnell Douglas following a 1987 accident. In the AD, EASA states concern that “some operator’s procedures no longer reflect the initial intent of the [McDonnell Douglas] recommendation...as the check is performed less frequently.” Readers may review the entire AD at the following website: <http://ad.easa.europa.eu/ad/2008-0197>

SOP are universally recognized as basic to safe aviation operations, as evidenced by the MD-82 example. In 2003, the FAA issued an advisory circular (AC) on SOP, AC 120-71A, “Standard Operating Procedures for Flight Deck Crewmembers”. In that AC, the FAA noted the following key features of SOP:

“KEY FEATURES OF EFFECTIVE SOP.

- a. Many experts agree that implementation of any procedure as an SOP is most effective if:
- (1) The procedure is appropriate to the situation.
 - (2) The procedure is practical to use.
 - (3) Crewmembers understand the reasons for the procedure.
 - (4) Pilot Flying (PF), Pilot Not Flying (PNF) / Pilot Monitoring (PM), and Flight Engineer duties are clearly delineated.
 - (5) Effective training is conducted.
 - (6) The attitudes shown by instructors, check airmen, and managers all reinforce the need for the procedure.”

In order to be most effective, operators should review OEM recommended procedures, define SOP, explain the reason behind the SOP, and effectively train SOP. Each operator should avoid a “double standard” between SOP as trained and as operated in routine practice. To do otherwise is to eliminate one of the most simple and effective hazard mitigations in flight operations. Readers may review the entire AC at the following website:

[http://rgl.faa.gov/Regulatory_and_Guidance_Library/rgAdvisoryCircular.nsf/0/b173ba8a295764f086256cde006a44ad/\\$FILE/AC120-71A.pdf](http://rgl.faa.gov/Regulatory_and_Guidance_Library/rgAdvisoryCircular.nsf/0/b173ba8a295764f086256cde006a44ad/$FILE/AC120-71A.pdf)

Recommended Action: Directors of Operations, Directors of Maintenance, Directors of Safety and Directors of Training should review their procedures to ensure that maintenance procedures and flight crew SOP are effective for ensuring proper operation of a TOWS. Operators of DC-9 series, MD-80 series, MD-90, and B-717 operators may refer to the OEM-recommended procedures for the TOWS. Operators of other airplanes should review their maintenance and flight crew SOP to determine if the procedures achieve a similar assurance of configuration warnings.

Directors of Operations, Directors of Maintenance, Directors of Safety and Directors of Training should ensure that their operations and maintenance personnel are effectively trained in and follow approved standard procedures for their aircraft.

APPENDIX 3
Safety Recommendation
REC 01/09

SECRETARÍA GENERAL DE
TRANSPORTESCOMISIÓN DE INVESTIGACIÓN
DE ACCIDENTES E INCIDENTES
DE AVIACIÓN CIVIL

SAFETY RECOMMENDATION

Reference: REC 01/09
Date: February, 25th, 2009

Background

On 20 August 2008 at 14:24, a McDonnell Douglas DC-9-82 (MD-82), registration EC-HFP, operated by Spanair, was involved in an accident immediately after takeoff at Madrid-Barajas Airport (Spain). The aircraft was destroyed as a consequence of the impact with the ground and the resultant fire. There were 154 fatalities, including the 6 crew members, and 18 seriously injured among the occupants of the airplane.

Prior to takeoff while on the runway threshold, the crew reported a problem with the RAT probe heater and returned to the stand to have it checked by company maintenance personnel. The pilots had noted an overheating of the RAT probe, while on the ground, with the DFDR recording temperatures as high as 104° C.

Once the aircraft returned to the stand, maintenance personnel verified the fault described in the ATLB, checked the Minimum Equipment List under the appropriate section for the Rat probe heating, and proceeded to open the circuit breaker that supplied electrical power to the heater of the probe. Once this was done, it was proposed and accepted that the airplane be dispatched. The information recorded on the DFDR during the subsequent taxi and takeoff run prior to the accident indicated a maximum probe temperature of 30° C.

Upon completion of this action, the aircraft was cleared for takeoff and, once airborne, reached a height of 40 feet above the ground before descending and impacting the terrain. Although the accident investigation has not yet been concluded, all available data show that flaps and slats were not set in takeoff configuration, resulting in the failure of the airplane to climb properly after takeoff. It also shows that the cockpit crew did not receive the automated takeoff configuration warning during the takeoff roll.

The day before, the crews had logged in the aircraft's ATLB two cases of the RAT probe overheating while on the ground. When company maintenance personnel checked for the problem, the fault was not present. They proceeded to conduct other checks on the system but did not detect any anomalies.

Discussion

The RAT temperature probe has a heating system that should be inhibited while the aircraft is on ground. The way the airplane detects that it is in ground or in flight is by means of a switch connected to the nose landing gear that provides a ground signal when the strut is compressed, and a flight signal when it is extended. This ground-flight signal is sent to a set of relays. Each of these relays provides a ground-flight signal to various systems that require it for proper operation. In accordance with the manufacturer's Wiring Diagram Manual (WDM), in the case of the RAT probe heater, its associated relay is R2-5 which, in addition to heating, also supplies information to the TOWS, the radio cooling fan and the AC cross tie. Although no determination has yet been reached as to why the TOWS did not sound and/or whether there was a fault with the R2-5 relay, the investigation has focused on the relationship between the R2-5 relay, the high temperature indication while the airplane was on the ground, and the failure of the TOWS to sound during the takeoff roll.

In page 1 of the chapter on anti-ice systems (30-30-00) of the airplane manufacturer's Aircraft Maintenance Manual (AMM), the section on "PITOT AND STATIC - TROUBLESHOOTING" lists the maintenance actions to take in order to detect the cause of a malfunction in the event of failures involving various heating devices, including temperature probe heating.

In the case of the RAT probe heater, it indicates the maintenance actions to be carried out so as to detect the cause of the fault only for cases in which the heater is not supplying heat to the probe when it should, but it does not specifically state what actions to take when the heater is supplying heat to the probe when it is not supposed to, that is, when the airplane is in ground.

The manufacturer acknowledges that there is no specifically named, dedicated section that addresses detecting the cause of temperature probe heating while on the ground. It does, however, note that there are multiple references in its AMM and in its WDM that show that RAT probe heating should be inhibited while the aircraft is on ground.

As for the Maintenance Manual, Boeing stated that there are several sections within AMM Chapter 30-30-00 that would be useful in detecting the cause of this fault. These sections contain a basic description of the RAT heating system along with electric circuit block diagrams that show the circuit and components, including the connection between the RAT and relay R2-5, and which identify the electrical wires and contact positions of relay R2-5.

Boeing also stated that applying similar reasoning to the contents of the section on "PITOT AND STATIC - TROUBLESHOOTING", intended to detect the cause of a fault in which the heater is not supplying heat to the probe when it should, would help to identify why heat is being supplied when the airplane is on the ground.

So as to gather practical information on the methods operators of this type of airplane use to detect the cause of this fault and its subsequent resolution, the investigation team consulted with various operators of MD airplanes and noted that, in general, there is no single set of

steps taken by maintenance personnel, even within the same operator, and that these steps, in many cases, depend on the maintenance personnel's own experience.

In light of this information, it may be concluded that there is no specifically named section, such as "High RAT Indications on the Ground", in the Maintenance Manual with the sole purpose of detecting the cause of a fault involving heating of the temperature probe while on the ground. It was noted that the information needed to detect said cause was contained in different paragraphs and block diagrams in a chapter in the Maintenance Manual (Chapter 30-30-00), and could be supplemented by the Wiring Diagram, which required additional work by maintenance personnel to interpret this information so as to locate the cause of the fault.

Therefore, the steps to be taken are not specifically named in the manufacturer's maintenance manuals, for this specific issue, and some reliance is placed on the maintenance personnel's ability to look for and interpret the information.

The instructions for the ongoing airworthiness of the aircraft, therefore, do not address with the same level of specificity, two possible anomalies that could occur involving RAT probe heating:

- No heat when required (while airborne).
- Improper heating, while on ground (as occurred in this case).

The following safety recommendation is therefore proposed.

Conclusions

It is recommended that the FAA and EASA require the manufacturer, Boeing, to include in its Aircraft Maintenance Manual (AMM) for the DC-9 and MD-80, the Troubleshooting Manual for the MD-90 and the Fault Isolation manual for the 717 series of airplanes, specifically identified instructions to detect the cause and to troubleshoot the fault involving the heating of the RAT temperature probe while on the ground.

